

# MAINTAINING AN AIR QUALITY MONITORING STATION

Air Quality Monitoring stations are equipped with specialized instruments that require maintenance in order to function optimally.



**South African  
Weather Service**

# Maintaining an ambient air quality monitoring station

Ambient air quality monitoring stations are equipped with specialized equipment and just like a car these instruments require regular checks and maintenance to ensure that it continues to operate and to ensure the accuracy of measurements and reliability of instrumentation.

Monitoring stations are checked and maintained on a regular schedule (see table 3.1) to ensure that the data we are receiving is accurate and reliable. Without accurate and reliable data, we will not be able to use the information collected.

Table 3.1: Maintenance checks and their frequency of an air monitoring station.

| Maintenance Type                            | Frequency                   |
|---|-----------------------------|
| Daily instrument QC checks                  | Daily                       |
| Station maintenance and Span and Zero audit | Bi-Weekly (Twice per month) |
| Multipoint instrument audit                 | 3 Monthly                   |
| Air conditioner service                     | 6 Monthly                   |
| External SANAS audit                        | Annual                      |
| Non-routine checks                          | As required                 |

# Daily instrument quality control checks

Desktop checks using the logging software are performed each day to ensure that the air monitoring instruments are still operating effectively. These checks are performed in two ways:

1. Data trend analysis

The trends of the data collected over the last 24 hours are plotted and analysed.

## Definition

Data trends: These are the patterns of data points over time. These patterns are a set of data that should follow a recognizable form.

These data plots need to display a recognisable pattern depending on the pollutant being monitored and the location. Each pollutant generally has its own recognisable pattern or characteristics that one would expect to see if an instrument is operating effectively.

A good example of such patterns is the data we receive from an ambient temperature monitoring instrument. It is expected that during the night temperatures will drop and as the sun rises during the day the temperature will gradually increase. This will give us a data trend that looks like a wave form, see fig 3.1.

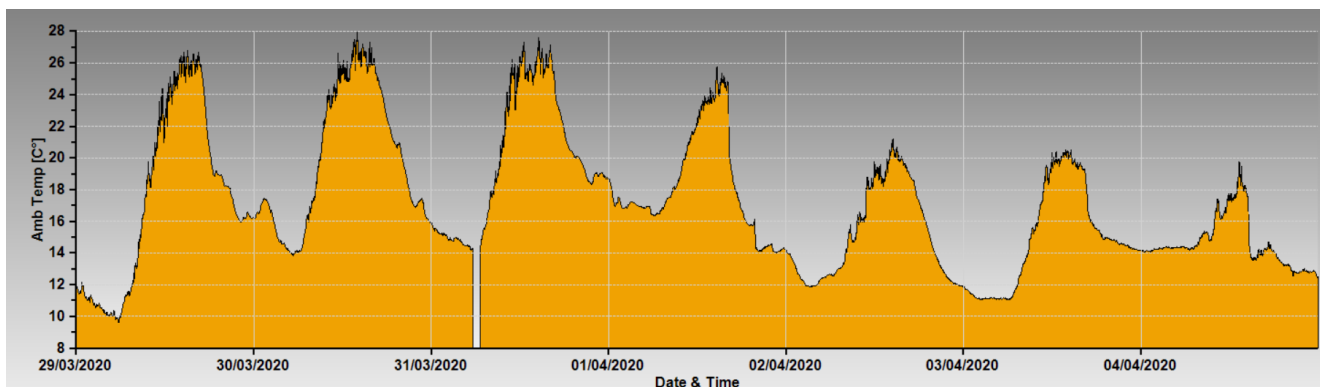

**Figure 3.1: Plot of ambient temperature over seven (7) days.**

These analyses are typically performed by experienced air quality scientists who are skilled in analysing and recognising air pollutant trends.

## 2. Instrument diagnostic checks

The diagnostics of each instrument is checked and verified that it is still within its expected operational range. The diagnostic checks are a direct check of the monitoring instrument and is very much dependent on the logging technology that is installed at that monitoring station (if we can remote into the logging computer or receive diagnostic parameters via the logging software).

| ~ Name ~          | ~ Value ~ | ~ Unit ~ |
|-------------------|-----------|----------|
| Flow Temperatur   | 16.39632  | Deg C    |
| Lamp Current      | 10.11353  | mA       |
| Digital Supply V  | 4.99009   | V        |
| Concentration V   | 0.2168274 | V        |
| PMT High Voltag   | 0         | V        |
| Gas Flow          | 0.4484882 | slpm     |
| Gas Pressure      | 681.7728  | Torr     |
| Ambient Pressur   | 694.0701  | Torr     |
| Cell Temperatur   | 0         | Deg C    |
| Converter Temp    | 0         | Deg C    |
| Chassis Tempera   | 32.21875  | Deg C    |
| Manifold Temper   | 0         | Deg C    |
| Cooler Temperat   | 50        | Deg C    |
| Mirror Temperat   | 0         | Deg C    |
| Lamp Temperatu    | 49.99417  | Deg C    |
| O3 Lamp Tempe     | 0         | Deg C    |
| Reference Voltag  | 2.859344  | V        |
| Calibration Press | 681.402   | Torr     |
| Converter Efficie | 100       | %        |
| Actual Pump Flo   | 0         | SLPM     |
| Lamp Current      | 0         | mA       |

Figure 3.2: List of diagnostics retrieved remotely from a logging computer.

The diagnostics for each monitoring instrument will further be explored in modules 4 - 8 where each instrument type will be explained.

The instrument checks are then logged into a daily check sheet and sent to the technicians responsible for that monitoring station. The daily check sheet is a brief overview of the status of your monitoring station giving an indication of the:

- Instrument status, **red**: not operational, **green**: operational
- Responsible, technician assigned to attend to the fault
- Comments, information to give further details of the fault reported

| Date       | Monitoring Station   |        |             |
|------------|--|--------|-------------|
|            | Instrument   | Status | Responsible |
| 06/04/2020 | BAM PM10   | Green  |             |
|            | BAM PM2.5  | Green  |             |
|            | SO2  | Green  |             |
|            | NO   | Green  |             |
|            | CO   | Red    | Technician  |
|            | O3   | Red    | Technician  |
|            | GC955 BTEX   | Red    | Technician  |
|            | TEKRAN Hg  | Black  |             |
|            | WS   | Green  |             |
|            | WD   | Green  |             |
|            | AMB. TEMP.   | Green  |             |
|            | ATM. PRESS.  | Green  |             |
|            | REL. HUM.  | Green  |             |
|            | SOLAR RAD.   | Green  |             |
|            | RAIN   | Green  |             |
| Comments   | Station is online. The O3 requires a new pump and a new uv-lamp, awaiting parts. CO was removed for repair. BTEX is displaying invalid readings and will be checked. |        |             |

Figure 3.3: Example of a daily instrument QC check sheet.

# Station routine maintenance

Apart from remotely checking the operation of instruments on a daily basis certain routine maintenance services needs to be performed on the instruments to insure accurate data and reliable monitoring. All instruments are provided with a service manual that indicates which parts require service at which interval, almost like a car is supplied with a service book.

Part of this maintenance is the bi-weekly maintenance that is performed on an air quality monitoring station.

## Bi-weekly routine maintenance

Every two weeks the operation of the monitoring station and all its subsequent equipment need to be assessed and the accuracy of the instrumentation verified to ensure the data we are receiving is true and accurate.

The basic maintenance of an air quality station can be broken down into three aspects that need to be checked;

- 1. Environmental Factors**
- 2. Supporting Devices**
- 3. Instrumentation**

## Activities process for routine maintenance visits

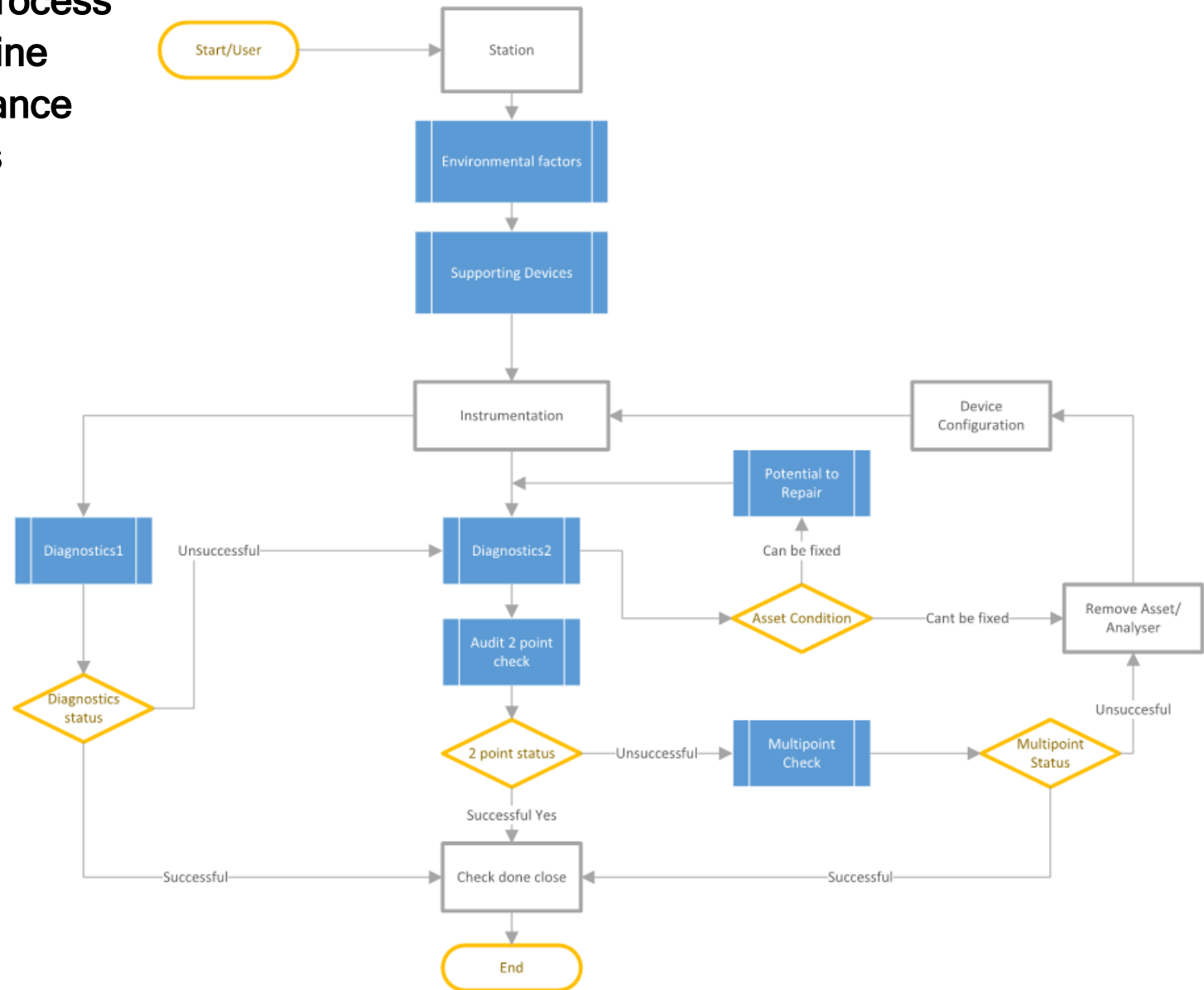

**Figure 3.4:** The above diagram represents the process flow for the maintenance of an air quality monitoring station.

## Step 1: Environmental Factors

Starting the maintenance certain parameters must be checked and verified to ensure the optimal environment is created for the instruments to function effectively.

These environmental factors include the following aspects that must be checked and verified.

### Environmental factors to be checked and verified:

- Is the **security fence** still in good order and the gate secure?
  - Security of the location is still intact. Yes/No
  
- Is the **grass/field** around the station cut and neat?
  - Good housekeeping. Yes/No
  
- Is the station door still **locked and secure**?
  - Security of the structure is still intact. Yes/No
  
- Is the condition of the station still good, is there any **water leaks**?
  - Moisture can damage the electronics; hence the station needs to be sealed and watertight. Yes/No
  - If there is evidence of moisture the station needs to be sealed (See Annexure A1 on Station sealing procedure)
  
- Is the Air conditioner set to the **correct temperature**?
  - Air conditioner setting: If the station is too cold or warm, condensation can form in the station or tubing of the instruments resulting in water damage.
  - The Air conditioner should be set to **25 °C** Yes/No



- Is the network operational and the logger connected to the **internet**?
  - All data from the instruments get transmitted to an external server. No internet = No live reporting of data.
  - Verify that there is internet connectivity on the logging PC and that the logging software is transmitting data. (See Annexure A2 on logger connectivity and transmission)

Yes/No
  
- Is the **sampling system** still in order?
  - Tubing that connects the outside air to the monitoring instruments. If not connected correctly or damaged the instruments will be measuring the air in the station and not Ambient Air.

Yes/No
  
- Check the **calibration/operational gas cylinder** pressures and verify readings from previous visits.
  - Certain monitoring instruments require gas (operational gas) to function. Must ensure they are set to the correct operating pressure and there is enough gas left in the cylinder.
  - If the station has a calibrator and gasses (calibration gas) for remote checks. Need to ensure they are set to the correct operating pressure and there is enough gas left in the cylinder.
  - (See Annexure A3 on calibration/operational gas cylinder checks procedure)

eg.  
BTEX =  
600kpi  
  
SO<sub>2</sub> =  
1500kpi
  
- Verify that the **Meteorological equipment** is still functioning and take note of the current readings.
  - Check the meteorological conditions against a handheld device. Record the current conditions
  - (See Annexure A4 on Meteorological equipment verification procedure)

WD =  
WS =  
AT =  
RH =  
SR =  
BP =  
RF =

If any of the environmental factors fail the checks, immediate action must be taken to rectify the problem. If immediate action is not possible the station can continue to operate, however the network manager or station owner must be informed, and the problem noted in the maintenance sheets and station logbook.

## Step 2: Supporting Devices

The next step is to check the supporting devices. These are all the devices that are used to ensure that the station and the environment for the instruments are in an optimal condition for accurate measurements. If specified supporting devices are not functioning correctly the station can no longer function as an accurate monitoring station and the problem needs to be corrected or the station switched off.

### Supporting devices to be checked and verified:

- Is there **electricity** at the station?
  - No power = No operation. Yes/No
  
- Is the **security system**, if present, operating correctly?
  - Alarm system for the station. Yes/No
  
- Is the **Uninterruptable Power Supply (UPS)** still functioning or is there an error being displayed?
  - To verify you can switch off the power at the distribution board and ensure that there is still a continued supply to the instrumentation (Usually performed 3 monthly). Yes/No
  - The UPS batteries can also be tested by performing a voltage test (See Annexure A5 on battery test procedure)
  
- Is the **Air conditioning system** functioning correctly?
  - The monitoring instruments must operate at a stable temperature between 20 - 30 °C. If the station is too hot or cold the instruments cannot operate, and all must be switched off. - Verify with internal temperature sensor or handheld device. Yes/No

- Is the logging system/computer operating and all data being logged?
  - All measurements (data) is recorded, stored and transmitted from the logging system. If this is not operating, we will not receive air quality data from the station. Yes/No
  - Verify that the data being received by the logging system matches with the data being displayed by the instruments.
  - (See Annexure A2 on logger connectivity and transmission)
  
- Is the sampling system operating correctly and all connections tight?
  - The blower motor must be operating, and all tubing sealed so that only ambient air is being sampled. If the blower motor is not operational the instrumentation will be sampling stagnant air and the measurements will be inaccurate.
  - The sample manifold, which connects the ambient air to the inside of the monitoring station must be unbroken and clean of dirt. Yes/No
    - Broken = could be sampling air from the station or letting in water
    - Dirty = Dust particles can absorb gasses; thus, the instrument will measure inaccurately.

(See Annexure A6 on sample system cleaning procedure)
  
- Is the ladder present and safe to use?
  - Required to get onto the roof of the station to clean the sample inlets, particulate filters and meteorological equipment. Yes/No

(See Annexure A7 on working at heights procedure)

Once the environmental factors and the supporting devices have been checked and verified, we can now be satisfied that the conditions in the monitoring station are optimal to ensure a suitable environment for measurements to take place. Further maintenance and checks can now be performed on the instruments to verify accuracy.

The below sheet is the standard maintenance sheet used to verify the environmental factors and supporting devices of an air quality monitoring station.

**SOUTH AFRICAN WEATHER SERVICE**  
Record of  
**ROUTINE SERVICE AND MAINTENANCE OF AIR QUALITY MONITORING STATIONS**  
In accordance with  
**SAWS QUALITY MANAGEMENT SYSTEM**

MONITORING STATION: \_\_\_\_\_ DATE: \_\_\_\_/\_\_\_\_/\_\_\_\_  
ARRIVAL TIME: \_\_\_\_\_ H DEPARTURE TIME: \_\_\_\_\_ H

ALL AREAS **NOT USED** ON THIS REPORT MUST BE CLEARLY CANCELLED

| On Entering the Station                          |           |  |      |  |      |
|--|-----------|--|------|--|------|
| Name of officer in charge of security            |           |  |      |  |      |
| State of the enclosure fencing                   | Good      |  | Fair |  | Poor |
| Enclosure temperature                            | 25 ± 5 °C |  |      |  |      |
| Remarks (Factors in the surrounding environment) |           |  |      |  |      |
|  |           |  |      |  |      |

**ROUTINE SERVICE:**

|                                       | Yes/No | Initials |                                | Yes/No | Initials |
|---------------------------------------|--------|----------|--------------------------------|--------|----------|
| Check online communication            |        |          | Cleaned inlet fans             |        |          |
| Check logger communication            |        |          | Cleaned glass inlet/FPM inlets |        |          |
| Check date and time logger            |        |          | Cleaned PM head inlets         |        |          |
| Changed SO <sub>2</sub> SIF           |        |          | Cleaned PM water trap          |        |          |
| Changed NO <sub>x</sub> SIF           |        |          | Inverter checked               |        |          |
| Changed CO SIF                        |        |          | Shelter Checked for Leaks      |        |          |
| Changed O <sub>3</sub> SIF            |        |          | All sample lines connected     |        |          |
| Changed BTEX SIF                      |        |          | Update Asset List              |        |          |
| Changed PM <sub>10</sub> Filter tape  |        |          | All analysers monitoring OK    |        |          |
| Changed PM <sub>2.5</sub> Filter tape |        |          | Site Entry Log Completed       |        |          |
| Check consumables                     |        |          | Lawn mowed                     |        |          |

|                  |                 |                     |                   |
|------------------|-----------------|---------------------|-------------------|
| Wind speed       | Wind direction  | Ambient temperature | Relative humidity |
| Ambient pressure | Solar radiation | Rainfall            | BTEX pressure     |

| Station Environmental Data |  |                  |  |
|----------------------------|--|------------------|--|
| Temp (Before)              |  | Temp (After)     |  |
| Pressure (Before)          |  | Pressure (After) |  |
| RH (Before)                |  | RH (After)       |  |

The deviation percentage was calculated with this formula:

$$\% \text{ Deviation} = \frac{\text{Instrument Response (ppb)} - \text{Audit Concentration (ppb)}}{\text{Audit Concentration (ppb)}} \cdot 100$$

Figure 3.5: Routine maintenance form for environmental and device checks

### Step 3: Instrumentation

Bi-weekly maintenance is required on monitoring instruments to ensure the accuracy of measurements and reliability of the instrument.

The activities required to be performed on gas monitoring instruments can be broken down into three actions;

1. Filter replacements
2. Diagnostic checks
3. Gas Analyser Instrument audit (Span/Zero checks)

#### Step 3.1: Filter replacements

All ambient instruments measuring gaseous components will have a particulate filter to prevent contamination of the instrument. Contamination of the filter can result in degrading of the instrument performance, including;

- Slow response time (Lower flow)
- Erroneous readings (Cell contamination)
- Temperature drift

To prevent this from happening the particulate filter is required to be replaced at every routine maintenance visit.

Care must be taken to ensure that there is no flow of air passing through the sampling system of the instrument when the filter is changed. This can be done by either selecting the correct operation mode on the instrument or switching off the pump to ensure there is no flow when the filter is removed.

Filter replacement will differ slightly depending on the brand of monitoring instrument being used. The filter holders of an instrument can either be built into the monitoring instrument or an independent external filter holder that is connected to the instrument via tubing.

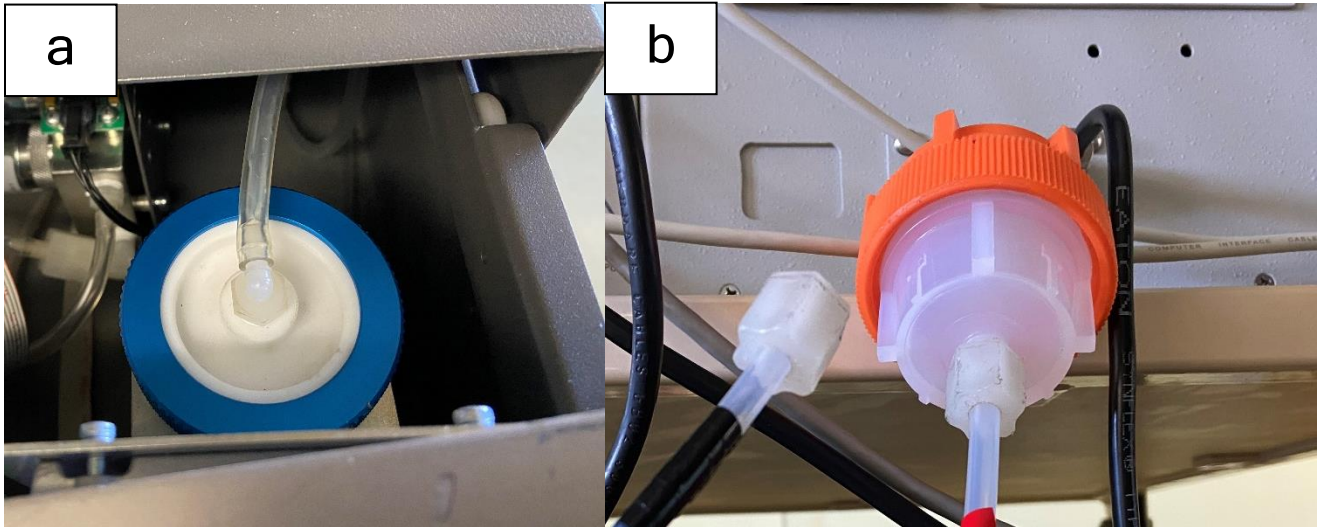
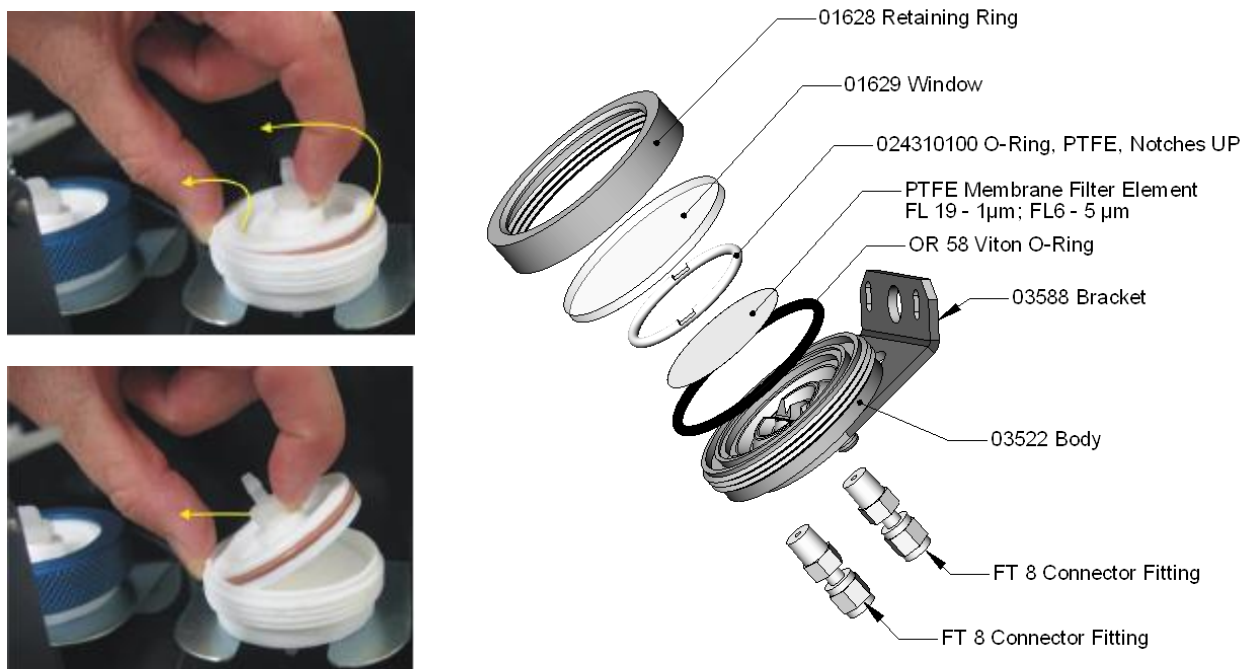

**Figure 3.6: Gas instrumentation internal (a) and external (b) filter holders.**

The filters that are used are specialized Teflon membrane filter elements with a 5 $\mu$ m pore size.



**Figure 3.7: Pack of teflon filters used for gas instruments**



**Figure 3.8: Example of particulate filter replacement.**

(See Annexure A8 on sample line filter replacements for the full procedure)

Once the particulate filter has been replaced, the instrument must be set back to the sampling mode and/or switch on the pump again to check the operation of the instrument under normal running conditions.

### Step 3.2: Diagnostic checks

Using the instrument's internal diagnostics, we check and verify that all parameters of the instruments internal components are within the normal operational range as per the manufacturer's standards.

Using the menus of the gas instrument, navigate through the diagnostic parameters and record the current status. The information that is recorded gives information on the voltages, temperatures, pressures and flows within the instrument. The diagnostics for each of the gas instruments will be described and explained in detail in modules 4 - 8.

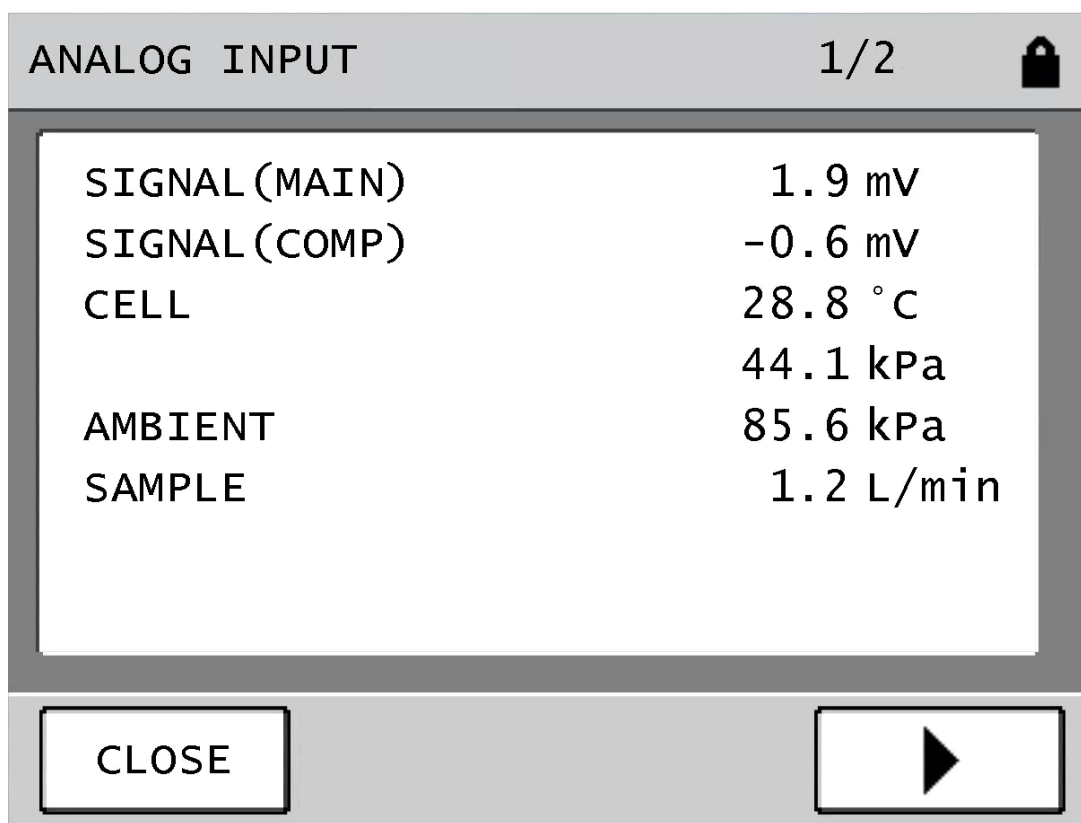

Figure 3.9: Example of the diagnostics menu on NOx analyser.



The diagnostic values observed in each of the measuring instruments need to be recorded in the maintenance sheet which is specific to an instrument brand and type.

Each diagnostic parameter has a set **functional range (Nominal range)**, which it is supposed to be within. If a diagnostic parameter goes out of that range the monitoring instrument is not functioning optimally and action must be taken to rectify the problem.

The readings observed on the monitoring instrument are recorded in the **observed** column of the diagnostic check sheet.

| Sulphur Dioxide Analyser |                                |              |                |           |
|--------------------------|--------------------------------|--------------|----------------|-----------|
| Manufacturer             | Horiba                         | Station Name |                |           |
| Model Number             | APSA-370                       | Operator     |                |           |
| Serial Number            |                                | Date         | /              | /         |
| Diagnostic Check sheet   |                                |              |                |           |
| SO2 Parameter            | Nominal value/ <u>range(1)</u> | Observed     | Updated Values | Deviation |
| Range (ppb)              | 0 - 1000                       |              |                |           |
| Signal main (mV)         | current                        |              |                |           |
| Lamp intensity (mV)      | 200 - 1200                     |              |                |           |
| Cell Temp (°C)           | ambient + 5 °C to 15 °C        |              |                |           |
| Pump pressure (kPa)      | 65 or less                     |              |                |           |
| Ambient pressure (kPa)   | current                        |              |                |           |
| Sample flow (L/min)      | 0.6 - 1.0                      |              |                |           |
| DC.24V (V)               | 24 ± 0.5                       |              |                |           |
| DC.5V (V)                | 5 ± 0.5                        |              |                |           |
| Alarm                    | current                        |              |                |           |
|                          |                                |              |                |           |

**Figure 3.10: Routine maintenance form for diagnostic checks**

With the new dust filter installed and the diagnostics all within the manufacturer's specifications we can be confident that the instrument is operating satisfactorily. The instruments can now be tested to verify the accuracy of the measurements by performing audit checks on the instrument.

### Step 3.3: Gas Analyser Instrument audit (Span and Zero checks)

To ensure the accuracy of any measuring instrument it needs to be verified against a set Standard Method with the use of Certified Reference Material (CRM) and Certified Equipment

#### Definition

**Standard method:** This is a set technique or procedure that is used to confirm the accuracy of a measuring instrument.

**Certified reference material (CRM):** This is your reference gasses, eg cylinder of SO<sub>2</sub> gas that is used to verify your measurement instrument against. This gas is required to be traceable to an international standard.

**Certified equipment:** Dilution calibrator whose accuracy has been verified/certified by an accredited laboratory.

Zero and span checks can also be referred to as an accuracy check, it is important to note that there is a difference between an accuracy check and a calibration.

- Accuracy check: no adjustments/corrections are made to the measuring instrument
- Calibration: only performed when the instrument is adjusted/corrected to measure the correct known concentration

During both, the same method is used to verify the measurements against a known concentration. Calibrations are only performed when the instrument is adjusted/corrected to measure the correct known concentration whereas during an accuracy check no adjustments are made.

Zero and span checks are performed on a bi-weekly schedule to verify the accuracy and validity of the measurements. Two instruments are required to perform these accuracy checks, a zero-air generator and a dilution calibrator.

As described in module 2, the Zero Air generator is an instrument which generates pressurized air using a pump and ambient air to compress the air. Scrubbing material such as Purafil and Activated charcoal is then used to scrub impurities from the ambient air to produce “clean air” or also referred to as zero air.

The zero air is also used in conjunction with the dilution calibrator to dilute high concentration gases to a known low concentration gas which is used to perform a span check on the instrument.

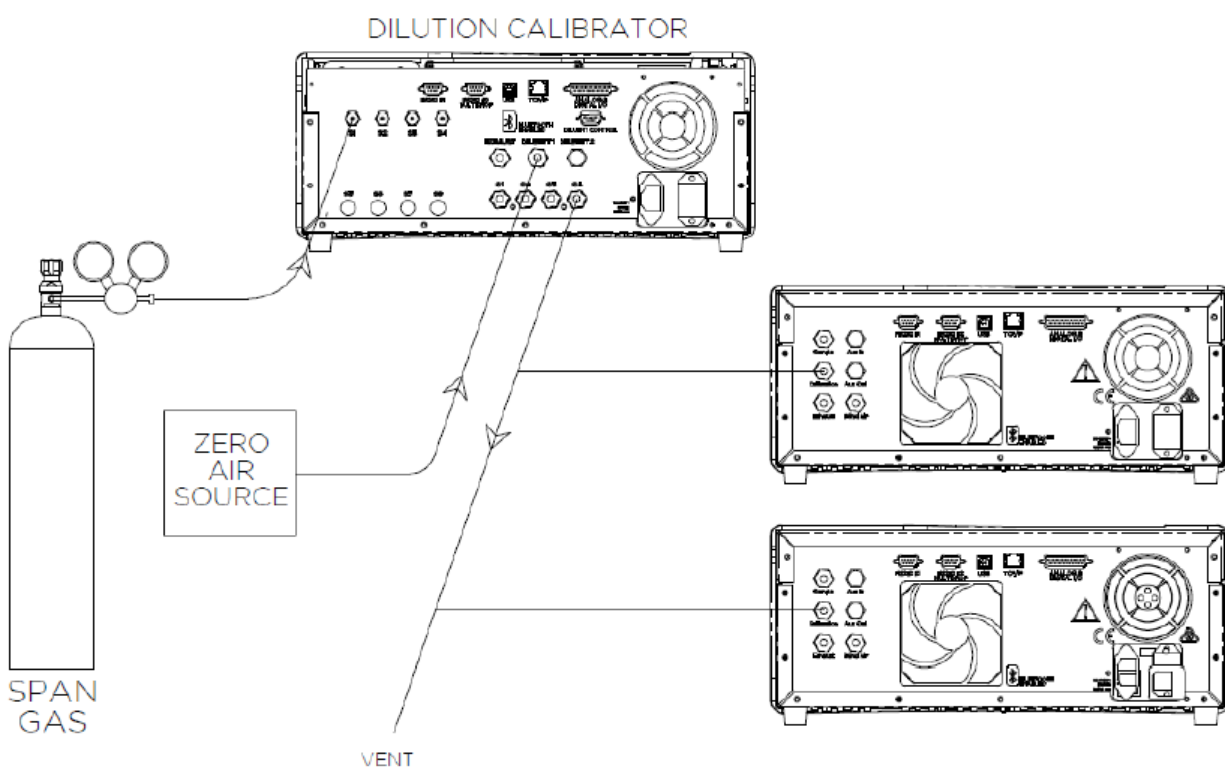

Figure 3.11: Example of the setup using a zero-air generator and dilution calibrator.

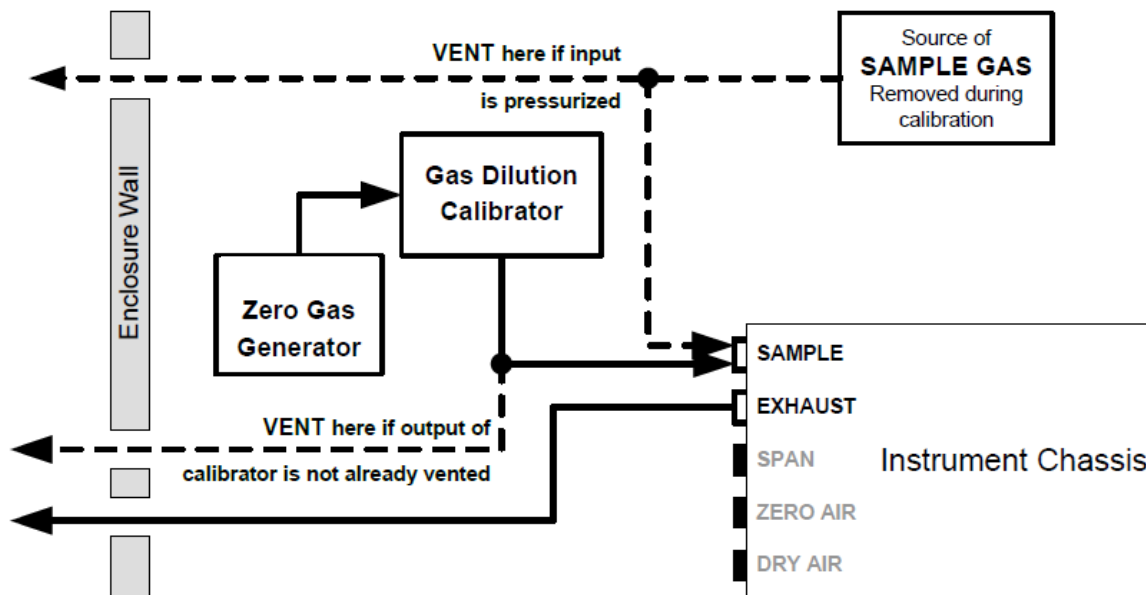

Figure 3.12: Gas line connections for a basic instrument audit setup.

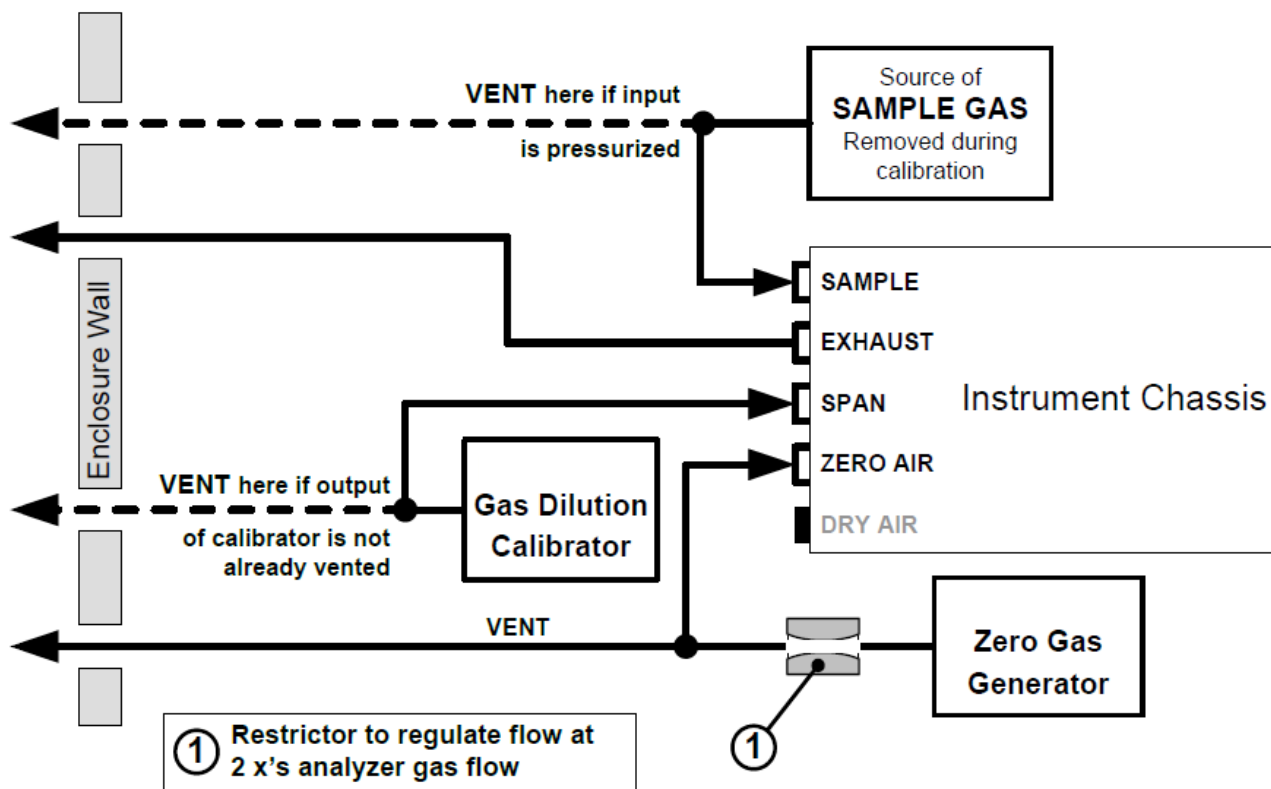

Figure 3.13: Gas line connections for analysers with Zero/Span valve options.

### 3.3.1 Gas Instrument audit - Zero checks

When performing an accuracy check the zero or base of the instrument is usually checked first. Due to some uncertainty that exist within instrumentation and user error there is an allowable range when a zero check is performed.

This allowable variance depends on the instrument and type of pollutant being measured but generally the zero point can be any value between  $0 \pm 2$  ppb. When an accuracy check is performed the instrument readings must be stable before the measurement is accepted, once zero air is applied to the instrument it generally takes an instrument about 15 minutes to stabilize but times vary.

The zero check can be separated into three distinct characteristics;

- Zero Measure: This is the period at which zero air is first introduced into the measurement instrument. The sample air is being removed and a reduction in measurement values will be observed.
- Zero Stabilize: At this point only zero air is being measured by the instrument and the reading value being measured should be stable.
- Zero Adjust: If the measured value is above or below the instrument's uncertainty value the instrument will need to be corrected. This correction is performed on the measurement instrument by correction/adjusting the zero value to read zero.

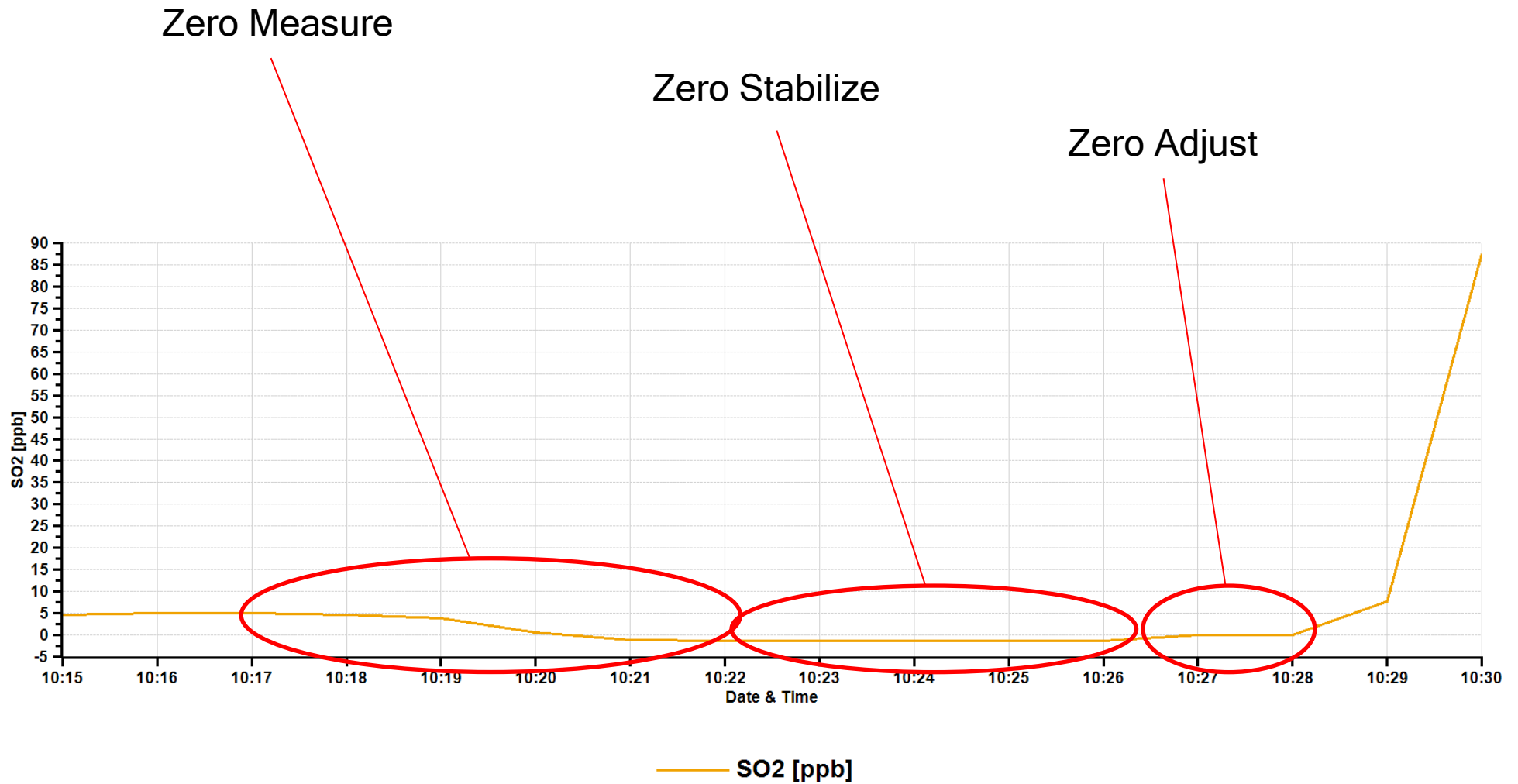

Figure 3.14: Example of performing a zero-point accuracy check.

### 3.3.2 Gas Instrument audit - Span checks

Span checks is an accuracy check that is performed at the upper end of the instrument's measurement range. The span check is performed at 80% of the measuring instruments full scale operating range. The operating range is dependent on the specific instrument type.

#### Example

The instrument range for an SO<sub>2</sub> gas analyser is commonly set as a default of 0 to 500 ppb. The span that will thus be performed on this instrument will be at 400 ppb, 80% of its 500 ppb full scale range.

All gas instruments have a manufactures range as stipulated in each instrument's manual. This range however can be adjusted to best suite the local conditions being observed.

When performing span checks the allowable variance depends on the instrument and type of pollutant being measured. Generally, the span point can be any value within  $\pm 2\%$  of the span value.

Span within  $\pm 2\%$  = PASS

Span out of  $\pm 2\%$  = FAIL - Adjustment is required

#### Example

If your span value is 400 ppb, the deviation allowed before an adjustment is required is  $\pm 8$  ppb. Hence the acceptable measured value will be between 392 ppb to 408 ppb.

When an accuracy check is performed the instrument readings must be stable before the measurement is accepted, once span gas is applied to the instrument it generally takes an instrument about 20 - 30 minutes to stabilize but times vary.

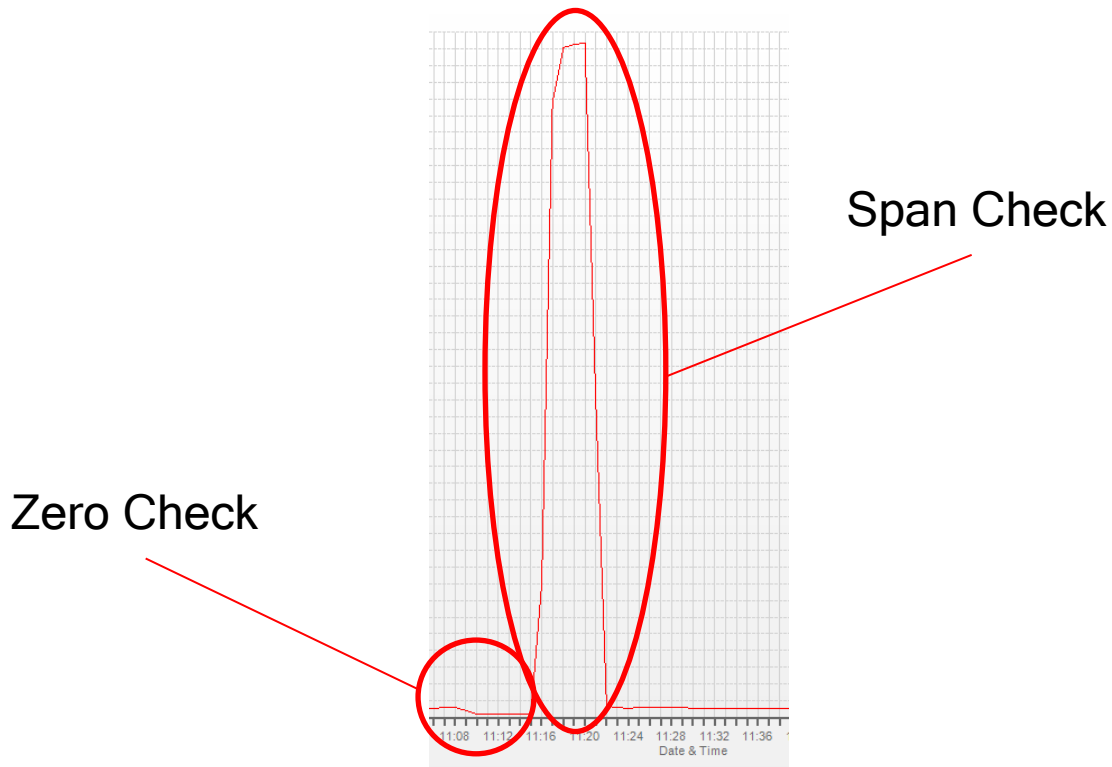

**Figure 3.15: Demonstration of a span spike when performing zero/span checks.**

The span check can be separated into three distinct characteristics;

- **Span Measure:** This is the period at which span is first introduced into the measurement instrument. The zero air from the zero check is being removed and an increase in measurement values will be observed.
- **Span Stabilize:** At this point, only span gas is being measured by the instrument and the reading value being measured should be stable.
- **Span Adjust:** If the measured value is above or below the instruments uncertainty value the instrument will need to be corrected. This correction is performed on the measurement instrument by correcting/adjusting the span value to read the 80% range value.



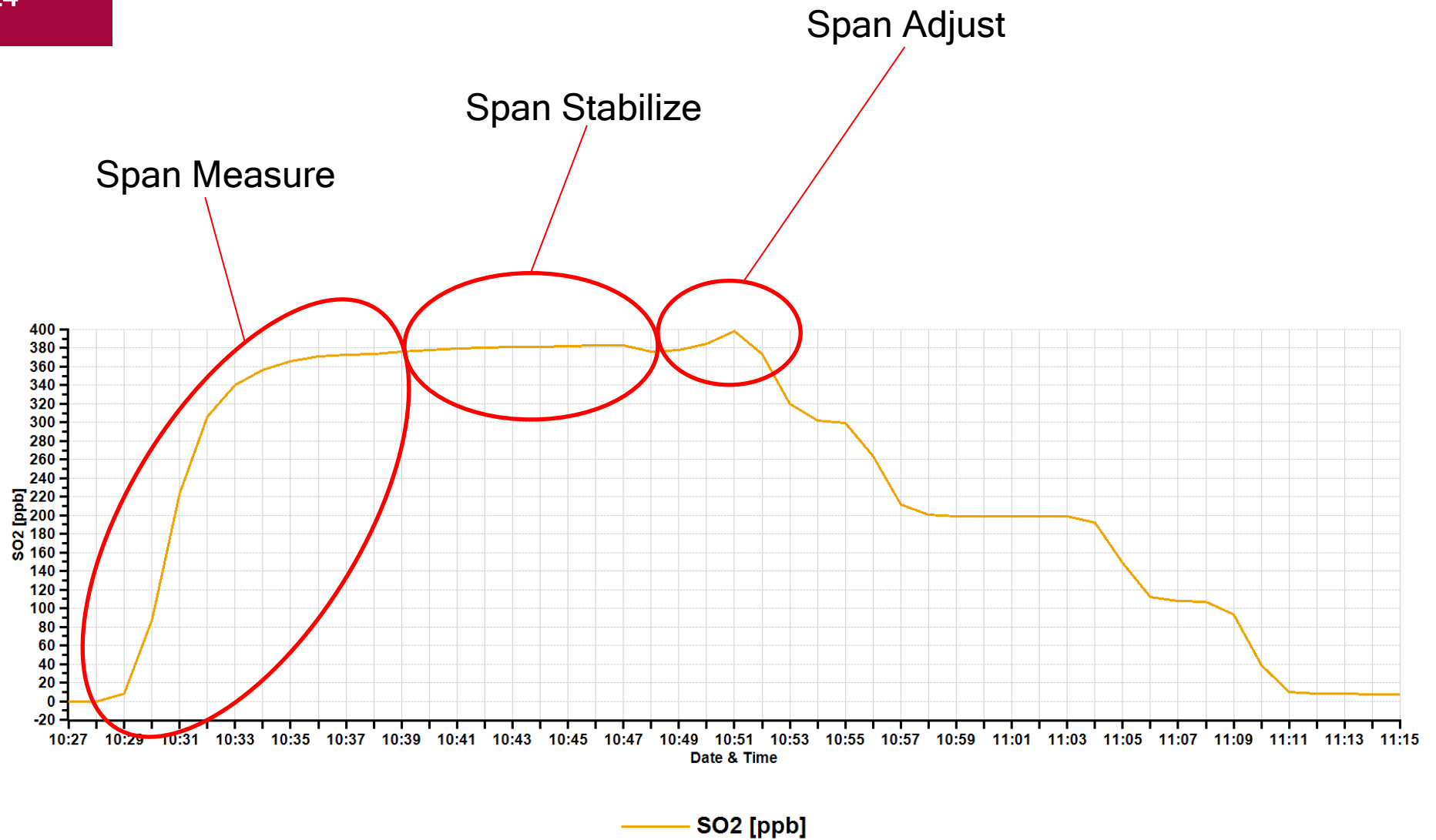

Figure 3.15: Example of performing a span-point accuracy check.

### 3.3.3 Gas Instrument audit - Multipoint Verification

If adjustments are made to the instruments span value, further verifications are then required. These verification checks are referred to as multipoint checks. A multipoint precision check is used to determine the linear response of the instrument across its operating range.

The instrument is supplied with span gas at multiple known concentrations, typically a zero point and at least four up/down-scale points (20%, 40%, 60% and 80%), spread across the operating range of the instrument. The observed concentrations are compared to expected values and the linearity of the instrument assessed against local applicable standards.

#### Example

Our SO<sub>2</sub> gas analyser has a range of 0 to 500 ppb. The multipoint checks will then be set for;

Zero = 0 ppb  
 20% = 100 ppb  
 40% = 200ppb  
 60% = 300ppb  
 80% = 400ppb

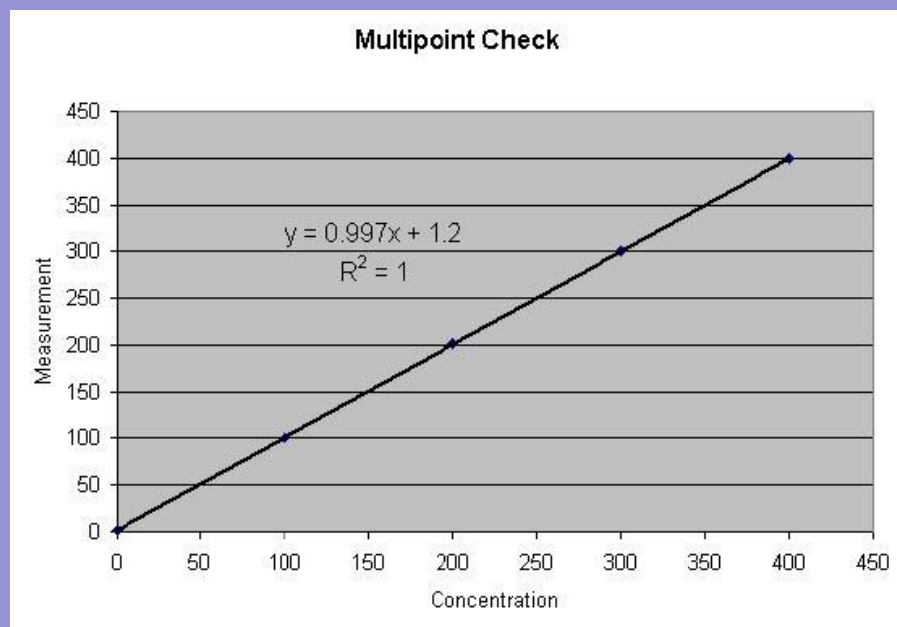

As per the allowable variance for the span point, the same  $\pm 2\%$  deviation is accepted for the instrument to pass the multipoint verification.

**MultiPoint's out of  $\pm 2\%$  = FAIL - Instrument requires repair**

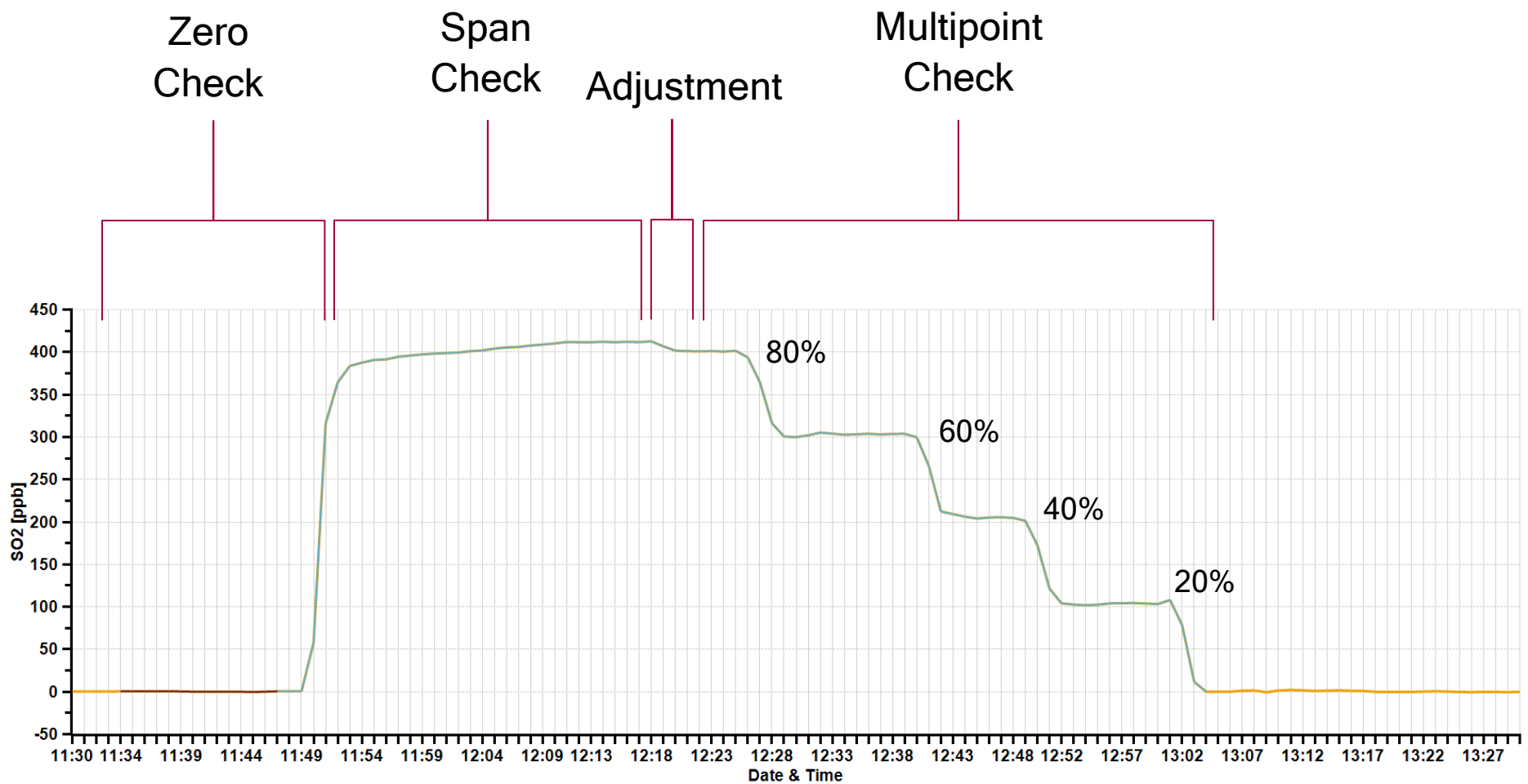

Figure 3.16: Example of performing a multipoint precision check.

The span/zero checks and multipoint precision checks performed on each of the measuring instruments need to be recorded in the maintenance sheet.

The readings observed on the monitoring instrument and the calibration unit are recorded;

- Actual & Target Flow: This is the output flow from the calibrator during the span/gas checks. This reading is observed from the calibrator and is verified additionally using a flow meter to ensure the accuracy of the calibration unit.
- Zero Actual & Target Flow: This is the output flow from the calibrator during the zero checks. This reading is observed from the calibrator and is verified additionally using a flow meter to ensure the accuracy of the calibration unit.
- Required response: This is our expected value that we wish to observe from the measurement instrument.
- Initial Instrument response: This is the actual measured value from the instrument during the span/zero check after the instrument has stabilized.
- Initial deviation: This is the percentage deviation between the expected and observed values to verify if the measured value is within the allowable variance.
- Final instrument response: This is the final value if adjustments have been made to the instrument's measurements.

| Zero & Span Check   | Span Setting           | Actual & Target Flow                                     | Zero Actual & Target | Required Response | Initial Instrument Response | Initial Deviation                         | Final Instrument Response | Adjustment Made |    |
|---|------------------------|--|----------------------|-------------------|-----------------------------|---|---------------------------|-----------------|----|
|   |                        |  |                      |                   |                             |   |                           | Yes             | No |
| Zero/Charcoal   | 0                      |  |                      |                   |                             |   |                           |                 |    |
| Span/Gas  | 80%                    |  |                      |                   |                             |   |                           |                 |    |
| Span/Gas  | 60%                    |  |                      |                   |                             |   |                           |                 |    |
| Span/Gas  | 40%                    |  |                      |                   |                             |   |                           |                 |    |
| Span/Gas  | 20%                    |  |                      |                   |                             |   |                           |                 |    |
| Cal Duration  | Zero                   | $T_{iF}$   | $T_{iF}$             | t=10min           | span                        | $T_{iF}$                                  | $T_{iF}$                  | t=10min         |    |
| <b>Remarks:</b>   |                        |  |                      |                   |                             |   |                           |                 |    |
| <b>Error Extent and Corrective Action</b>   |                        |  |                      |                   |                             |   |                           |                 |    |
|   | <b>Accept data</b>     | <b>Adjust instrument and report deviation*</b>           |                      |                   |                             | <b>Raise CAR, flag or invalidate data</b> |                           |                 |    |
| Zero  | $0 \pm 2\text{ppb}$    | $\geq 2\text{ppb}$ from zero but $\leq \pm 25\text{ppb}$ |                      |                   |                             | $\geq 25\text{ppb}$ from Zero             |                           |                 |    |
| Span  | Maximum Span $\pm 2\%$ | Deviation from Maximum Span $\geq 2\%$ but $\leq 7.5\%$  |                      |                   |                             | Deviation from Maximum Span $\geq 7.5\%$  |                           |                 |    |
| Multi-point Calibration Verification  | Maximum Span $\pm 2\%$ | Deviation from Maximum Span $\geq 2\%$ but $\leq 7.5\%$  |                      |                   |                             | Deviation from Maximum Span $\geq 7.5\%$  |                           |                 |    |
| * Adjustment requires multipoint calibration (zero, span and three intermediate points) using gas dilution calibration procedure. |                        |  |                      |                   |                             |   |                           |                 |    |

**Figure 3.17: Routine maintenance form for span/zero checks**

END