

OZONE (O₃) INSTRUMENTS

Ozone is a critical pollutant causing health risks and needs to be monitored using specialized instrumentation.



**South African
Weather Service**

What is Ozone

Ozone, or trioxygen, is an inorganic molecule with the chemical formula O_3 . It is a pale blue gas with a distinctively pungent smell. Ozone is formed from dioxygen by the action of ultraviolet (UV) light and electrical discharges within the Earth's atmosphere. It is present in very low concentrations throughout the latter, with its highest concentration high in the ozone layer of the stratosphere, which absorbs most of the Sun's ultraviolet (UV) radiation.

Definition

Ozone is an inorganic molecule with the chemical formula O_3 .

It is a toxic gas and the odour is reminiscent of chlorine, and detectable by many people at concentrations of as little as 0.1 ppm in air. O_3 is a very strong oxidizing agent.

The chemical composition of Ozone is written as O_3 which tells us that this gas consists of three Oxygen molecules.



O_3 is a bent molecule with C_{2v} symmetry (similar to the water molecule). The O - O distances are 127.2 pm (1.272 Å) and the O - O - O angle is 116.78°.

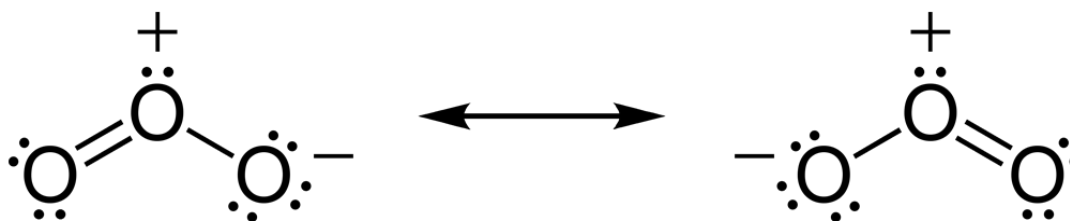

Figure 6.1: Representation of the two resonance structures of O₃.

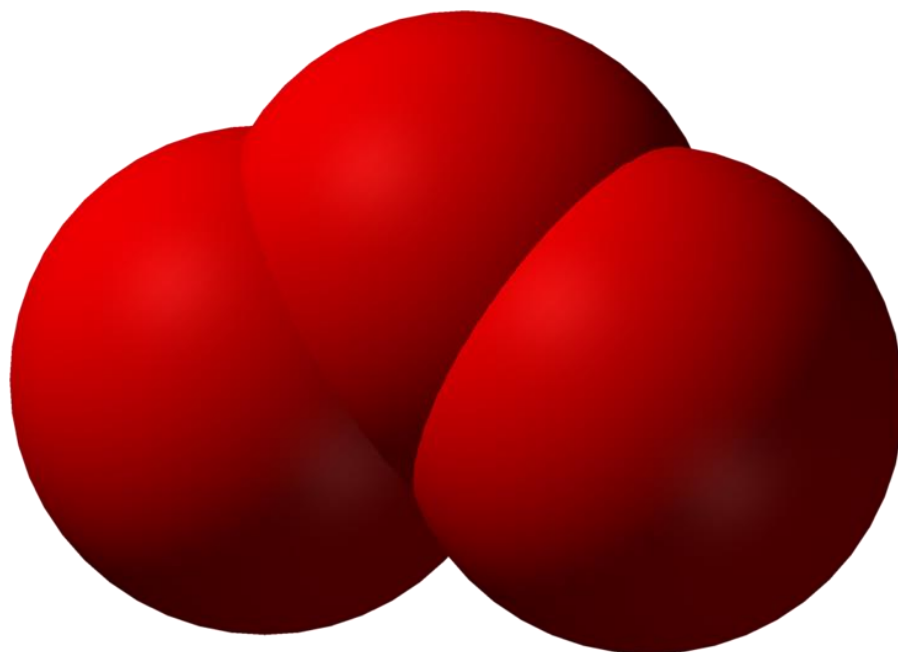

Figure 6.2: 3D representation of the chemical composition of O₃.

How do we measure O₃

The measurement of Ozone (O₃) in air is based on UV absorption analysis or UV spectroscopy.

Definition

UV spectroscopy is type of absorption spectroscopy in which light of ultra-violet region (200-400 nm) is absorbed by the molecule which results in the excitation of the electrons from the ground state to higher energy state

To enable us to measure trace levels of O₃ in ambient air we also make use of the principles of UV spectroscopy and certain components are required inside an instrument to do so. These basic components include:

- Electrical circuits to power the sensors and other circuits.
- Electronic circuits to measure voltages from sensors and circuits.
- Processor that can perform calculations and display data.
- Source that can emit ultraviolet light.
- Optical bench for the absorption to take place without interference.
- Sensor that can measure the remaining UV light.

Although several different type of O₃ analysers are available on the market and they are all manufactured by different suppliers most instruments make use of the same basic components and principle to measure O₃ in ambient air. To understand the principle of UV absorption/spectroscopy we first need to look at how ultraviolet light affects the O₃ molecules.

What is Ultraviolet light and how do we measure it?

Light is measured by its wavelength (in nanometers) or frequency (in Hertz). One wavelength equals the distance between two successive wave crests or troughs. Frequency (Hertz) equals the number of waves that passes a given point per second.

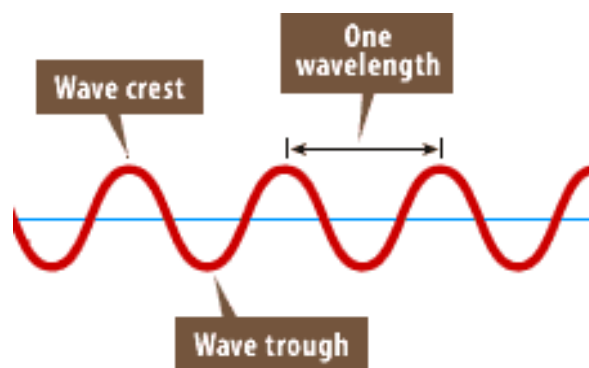

Figure 6.3: Light is measured in wavelength or frequency.

Definition

In physics, the wavelength is the spatial period of a periodic wave—the distance over which the wave's shape repeats.

Definition

Frequency is the number of occurrences of a repeating event per unit of time. It is also referred to as temporal frequency, which emphasizes the contrast to spatial frequency and angular frequency.

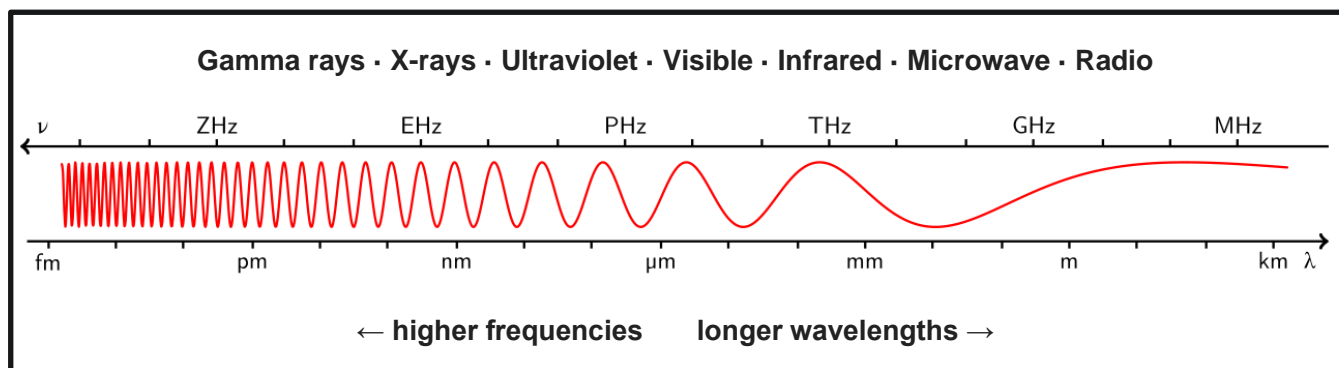

Figure 6.4: The full electromagnetic spectrum.

Light is measured at different wavelengths in nanometres, the electromagnetic spectrum for light is the available range of light that we can measure, the spectrum starts at a wavelength of 200 nM up to 20 μM. Ultraviolet light which is used for UV spectroscopy and which helps us to measure O₃ starts from 200 nM up to 400 nM, the visible light spectrum (VIS) that we see as colors is from 400 nM up to 700 nM. The next range of light is near infrared (NIR) which is measured from 700 nM up to 2 μM and the last spectrum of light is infrared light (IR) which is measured from 2 μM up to 20 μM.

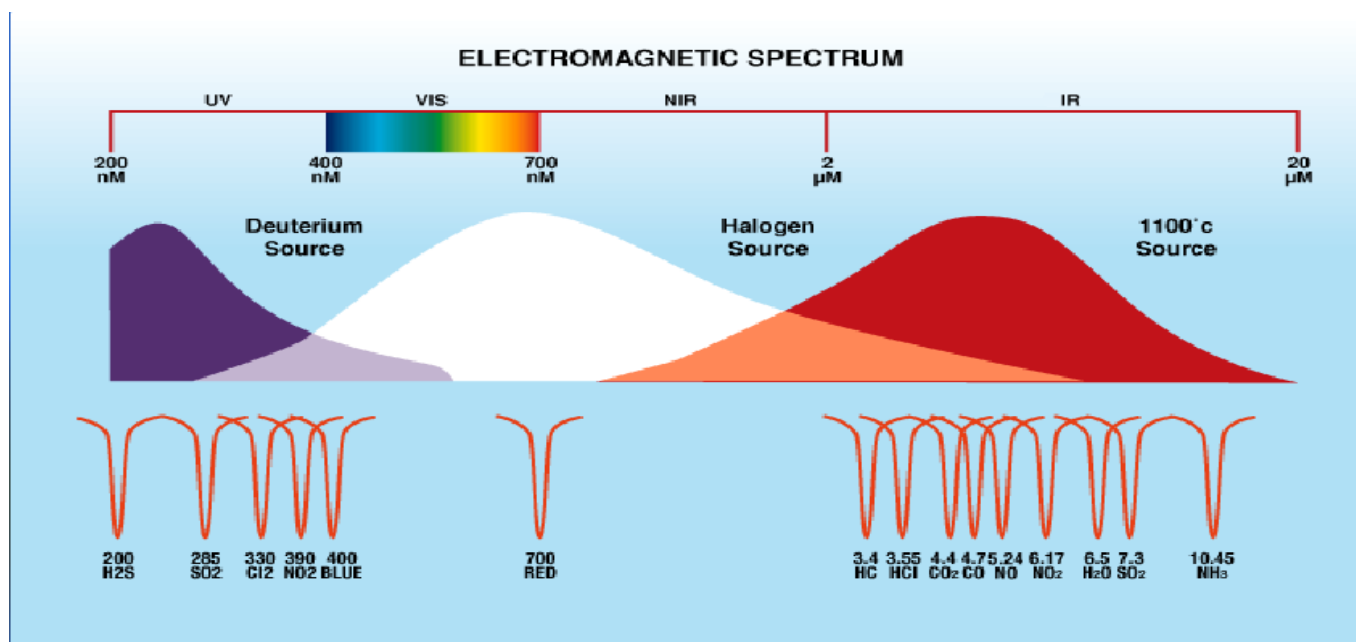

Figure 6.5: The electromagnetic spectrum of light.

Operation principles of O₃ instruments

UV spectroscopy in O₃ measurement is the excitation of O₃ molecules by using ultraviolet light, specifically from a Mercury lamp. The lamp emits UV light at a wavelength of 254 nm and this is absorbed by an O₃ molecule which in turn excites the O₃ molecule so that the molecule enters a different energy state.

The detector that is used in O₃ analysers is called a UV photometer which detects the UV light at a wavelength of 254 nm and can subsequently detect the amount of absorption that takes place within the sample cell. Using this simple method of only a UV photometer and a glass tube the instrument can accurately detect the amount of O₃ that is present in the sample tube by measuring the residual light after absorption has occurred.

Taking all of the above information into consideration we can measure O₃ molecules in air.

1. The light source emits UV radiation at a set wavelength of 254 nm which is used to excite the O₃ molecules in the sample so that the UV radiation is absorbed by the molecules.
2. The photometer constantly measures the intensity of the UV lamp and when O₃ molecules enter the absorption tube the intensity of the radiation from the lamp will be lower due to the absorption of UV radiation by the O₃ molecules.

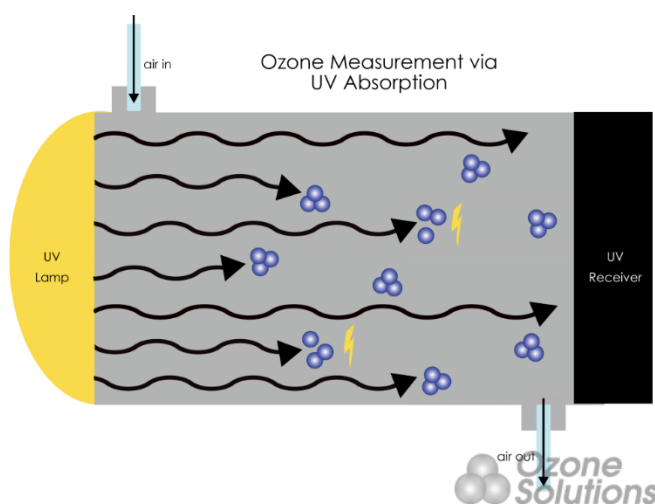

Figure 6.6: Operation principle of O₃ analysers.

Examples of O₃ instruments

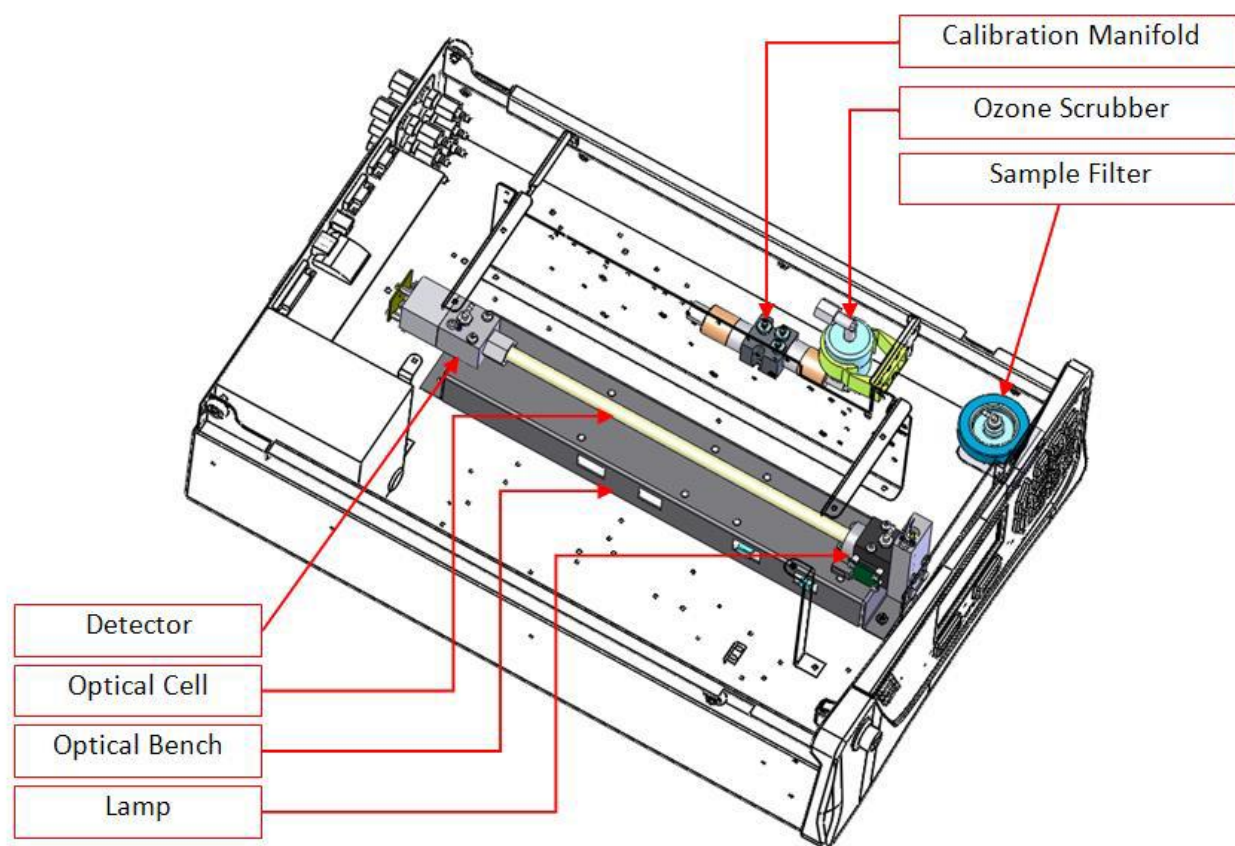

Figure 6.7: Example of the Ecotech Serinus 10 O₃ analyser.

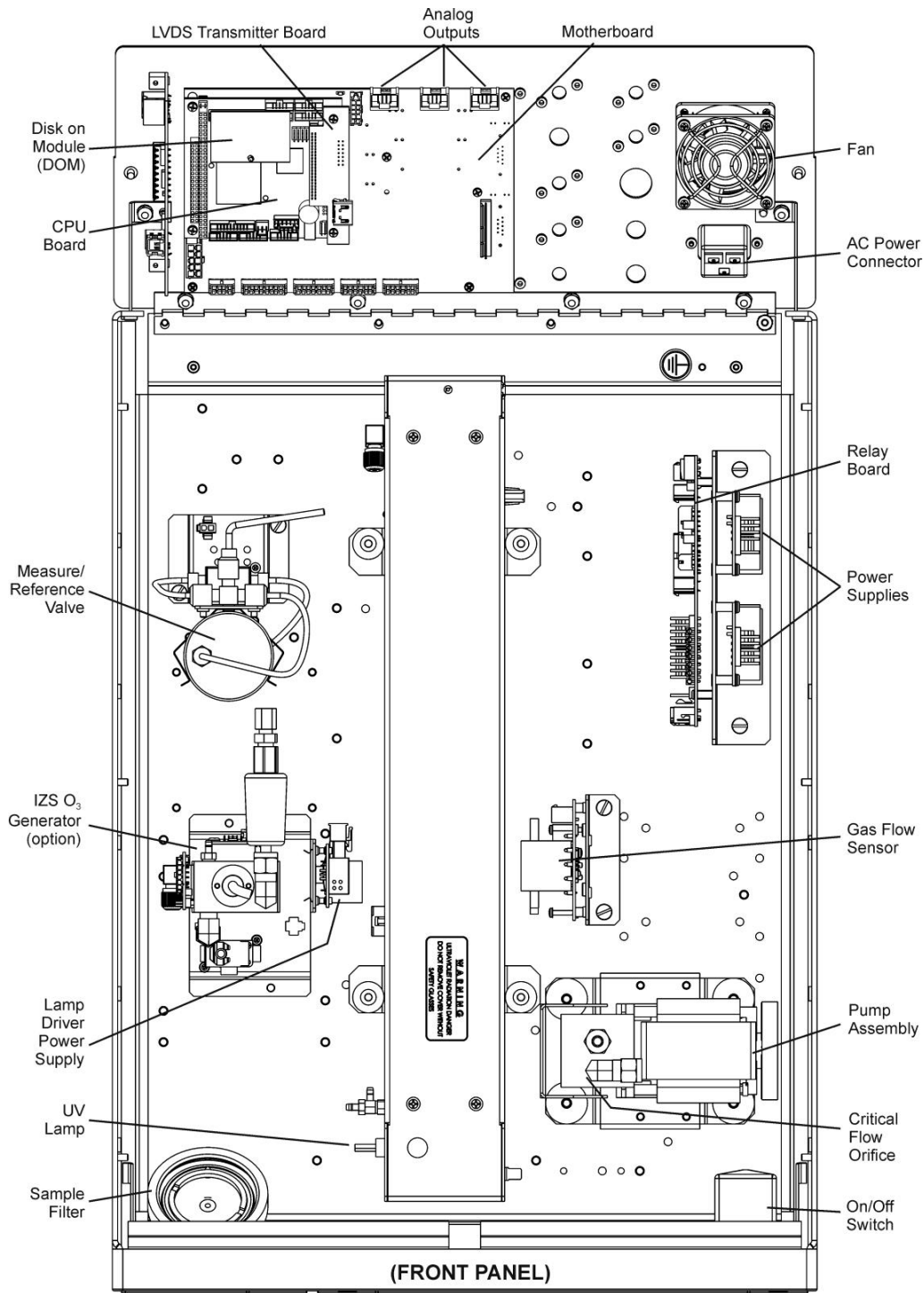

Figure 6.8: Example of API Teledyne T100 O₃ analyser.

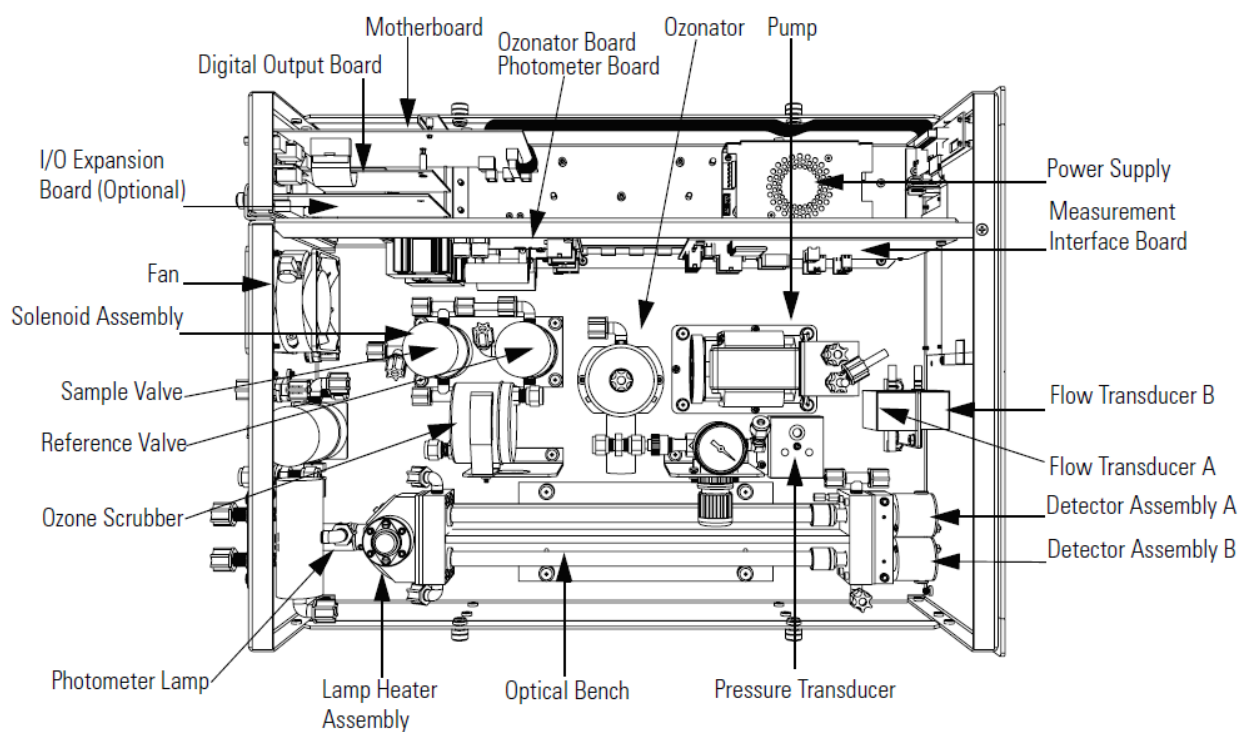

Figure 6.9: Example of Thermo Scientific O₃ analyser.

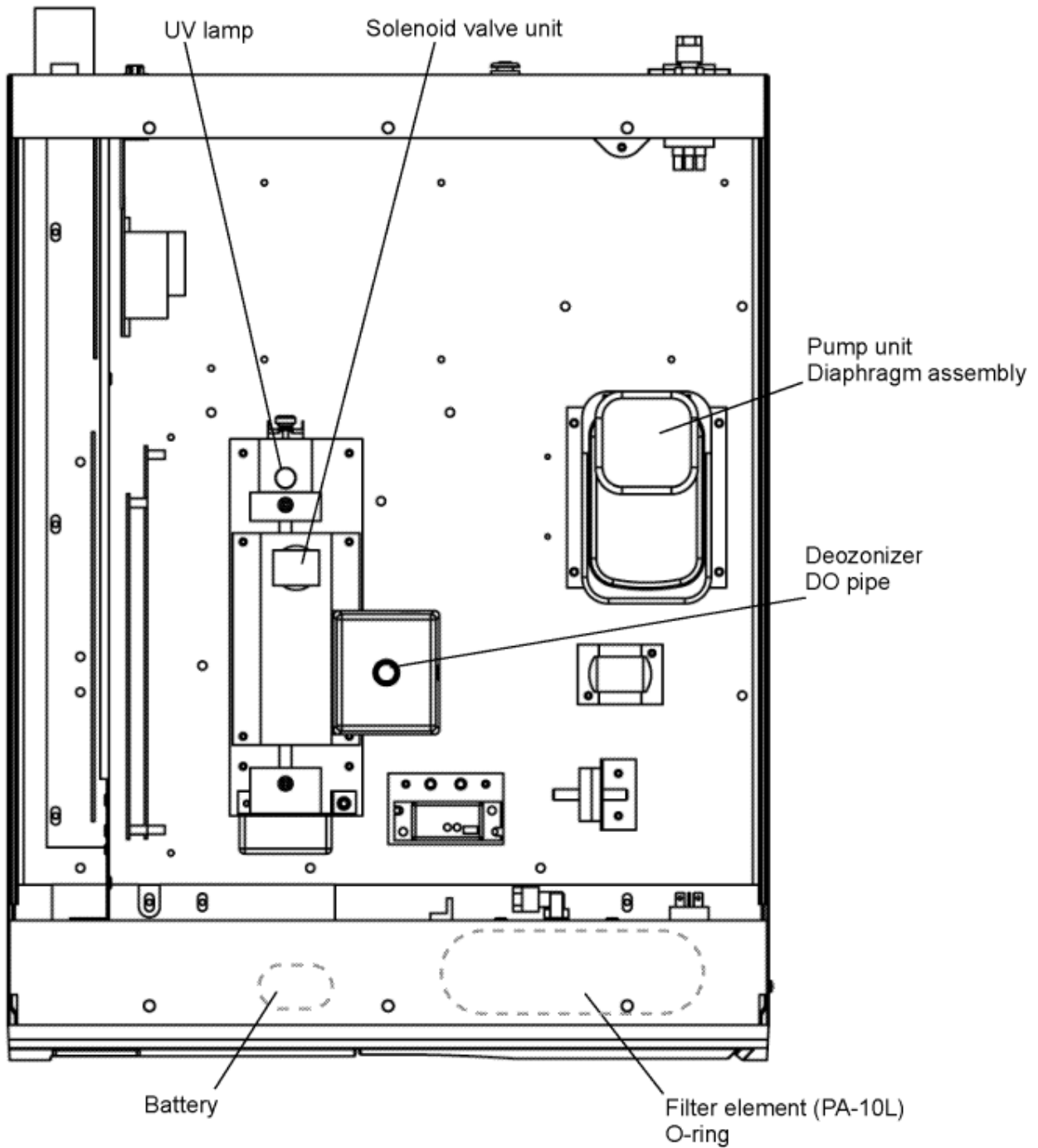
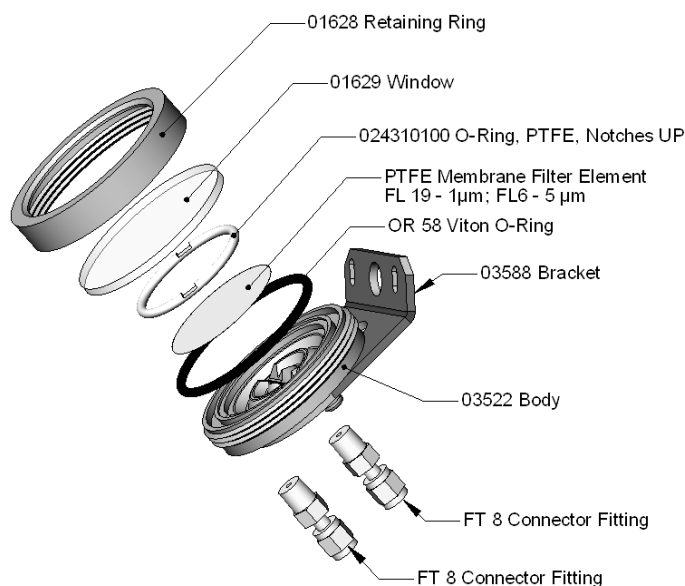
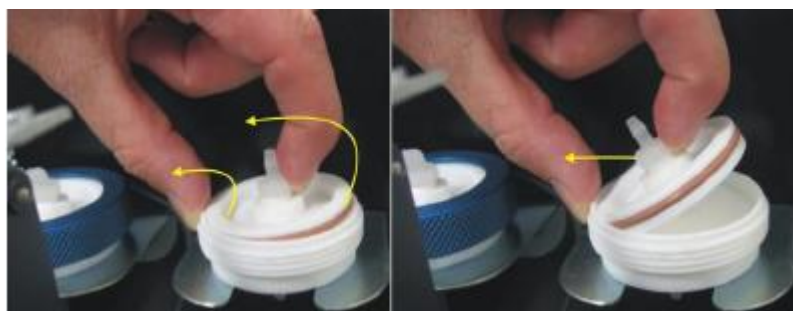

Figure 6.10: Example of Horiba APOA370 O₃ analyser.

Internal components of O₃ instruments

From the above examples several different internal components of the SO₂ instruments are shown, these internal components are used to ensure that the sample is delivered to the reaction chamber and that any impurities is scrubbed from the sample. Some of the internal components are discussed in further detail below.

Particulate filter



- All instruments will have a particulate filter. The filter is used to prevent contamination of the internal components of the instrument.
- Contamination of the filter can result in degrading of the instrument performance, including
 - Slow response time (Lower flow)
 - Erroneous readings (Cell contamination)
 - Temperature drift

Figure 6.11: Examples of particulate filters used in an O₃ analyser.

Valve block (Manifold)

During sampling or calibration of the instrument the flow of air needs to be redirected for a specific mode of operation. Valve blocks fitted with small electronic valves are used to control the flow of air as indicated by the user. The valve block can also be referred to as the zero/span/sample control block.

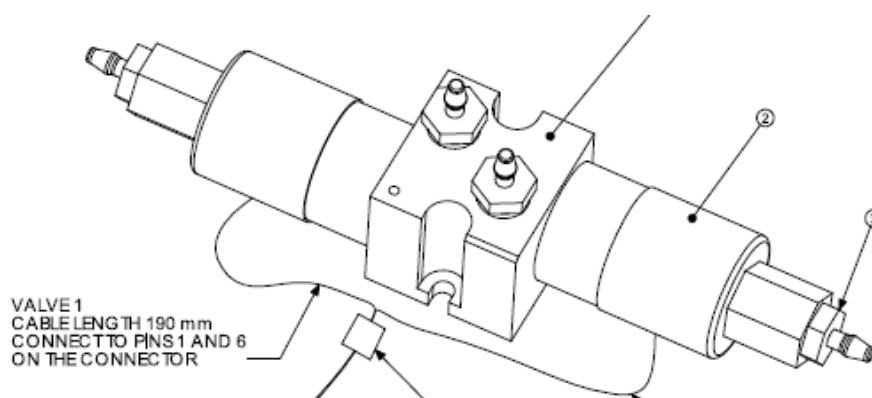
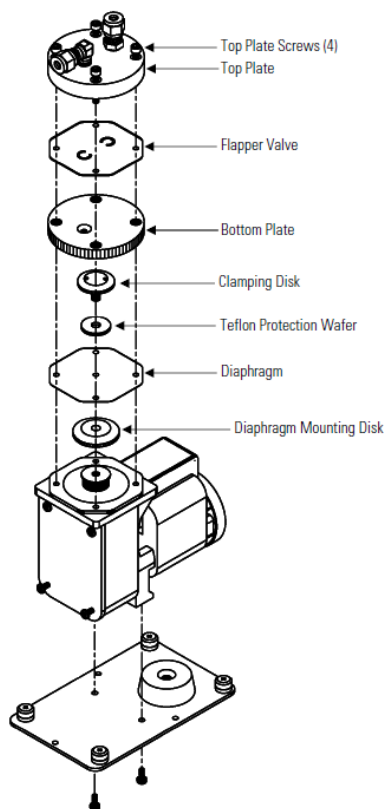

Figure 6.12: Example of valve block used in an O₃ analyser.

Pump



- All instruments require a source of flow to provide a sample to the reaction chamber. For this purpose a pump is used to draw a sample through the instrument.
- A pump can either be built into the instrument or be external and connected to the exhaust port.
- All gas instrument pumps are diaphragm pumps. Meaning a small piston pushes against a diaphragm creating a vacuum thus generating suction.

Figure 6.13: Example of a pump used to draw air through an O₃ analyser.

Ozone scrubber

Definition

Ozone scrubbers use manganese dioxide to scrub the ozone from the sample, providing a reference zero for the other channel.

The ozone scrubber uses manganese dioxide (MnO_2) to selectively destroy ozone in the sample air. This leaves the interfering ozone from reaching the optical cell and absorbing the UV radiation. This is performed by a manifold valve which periodically switches between the normal sample and a sample with no O_3 molecules to constantly provide a reference of the UV radiation being emitted by the Mercury lamp.

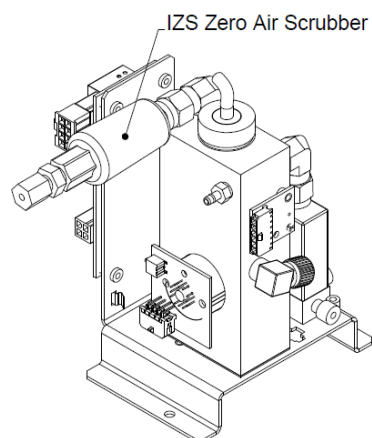
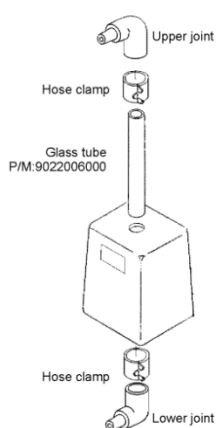

Figure 6.14: Examples of Ozone scrubbers used in an O_3 analyser.

Optical bench

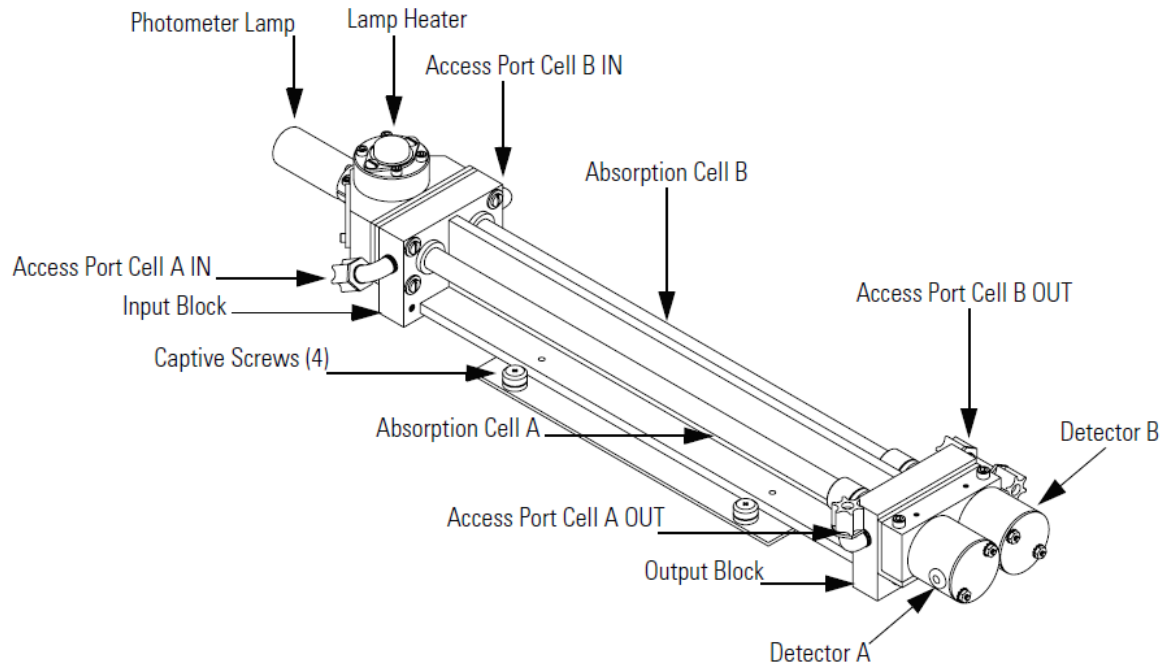

Figure 6.15: Example of the optical bench on an O₃ analyser.

The optical bench is where the UV spectroscopy takes place and where the measurement of the sample is performed, the reaction cell is usually made up of six main components:

1. Optical cell
2. UV Source
3. UV Detector

Optical cell

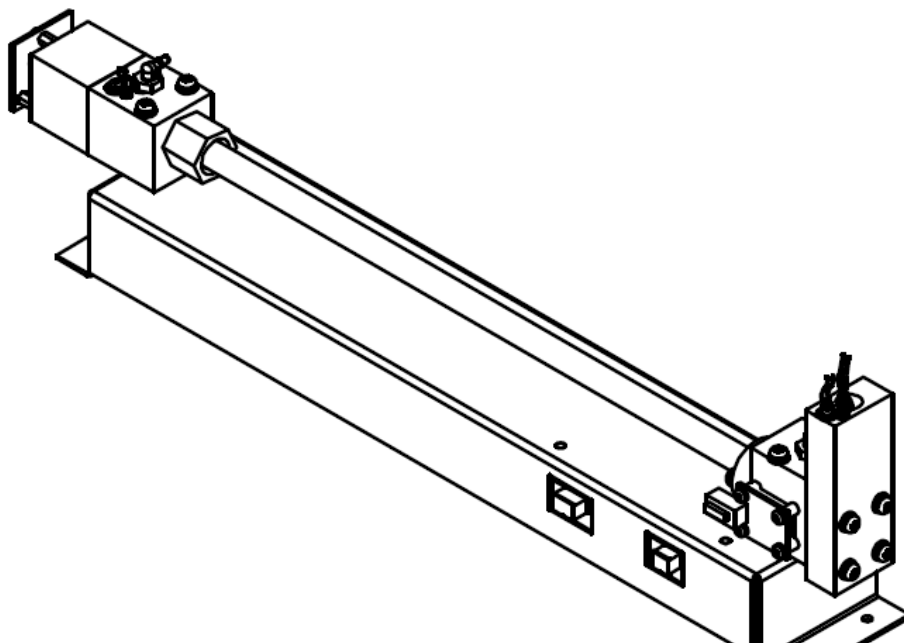

Figure 6.16: Example of the optical cell on an O₃ analyser.

This is the optical cell where the UV light at 254 nm is absorbed by the O₃ molecules inside the optical cell, the UV photometer can then accurately measure the amount of absorption that takes place by comparing the current reading from the photometer to the reference voltage saved in the memory of the instrument. The analyser periodically (normally every 6 seconds) switches between the reference sample and the normal sample.



O_3^* = Excited O₃ (cannot be measured by the photometer)

Light source (UV-lamp)

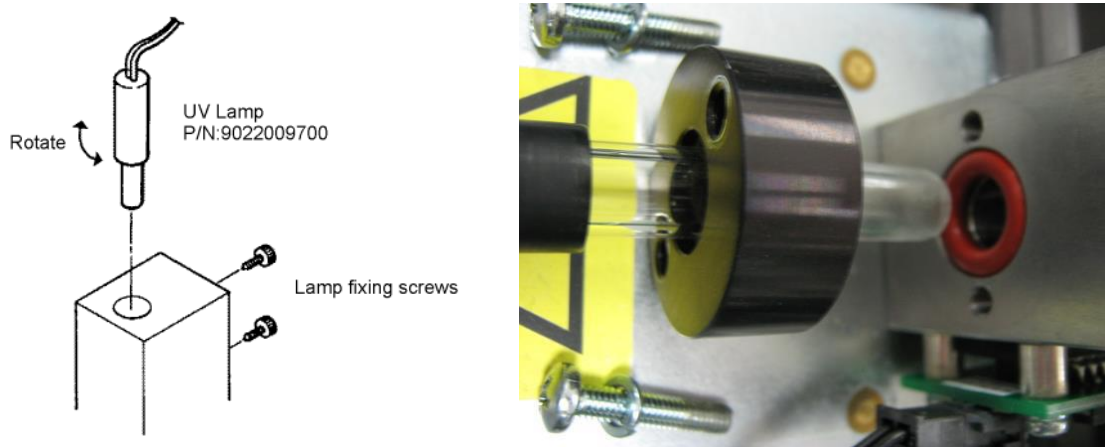

Figure 6.17: Example of the UV-lamp sources used in an O₃ analyser.

The light source used in O₃ analysers is a mercury lamp which emits UV light/radiation at a known wavelength of 254 nm.

Lamp position: the lamp output is not even across the length of the lamp and can be adjusted for optimal performance.

UV reference detector

The UV detector used in O₃ analysers is a vacuum diode that can only measure UV radiation of 254 nm. The mercury lamp which emits UV light/radiation at a known wavelength of 254 nm is directly measured by the UV detector and any radiation that was absorbed by the O₃ molecules in the sample cannot be measured, only the residual radiation is measured.

Flow of an O₃ molecule inside the instrument

With the knowledge of the principles of operation and all the internal components used inside an O₃ analyser we can piece together the flow of how an O₃ molecule is measured.

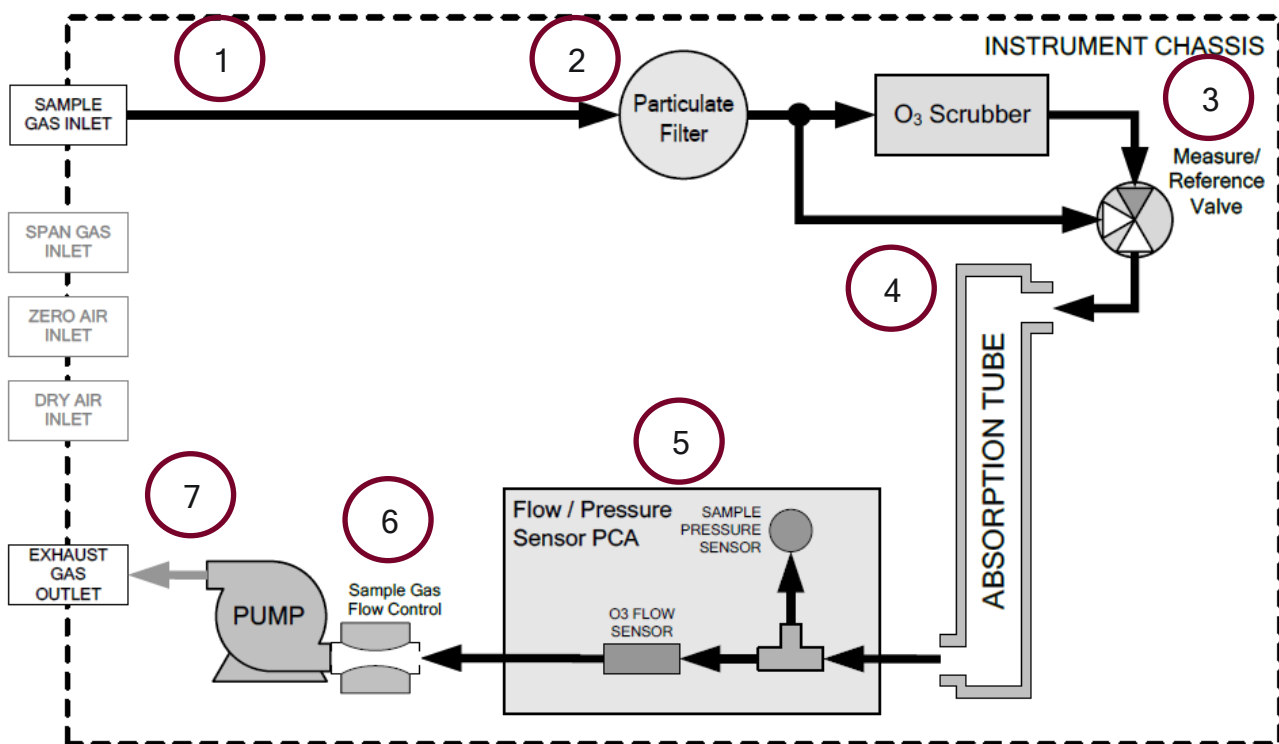

Figure 6.18: Flow process inside an O₃ analyser.

1. The sample enters the sample inlet due to the suction created by the pump on the opposite side of the process. The pump is always the final component in the flow process as the pump needs to create a flow of air through the instrument.
2. Once the sample has entered the inlet the sample filter first removes any small dust particles that can influence or contaminate the operation of the instrument.
3. The sample will split and on part of the sample will pass through the Ozone scrubber to scrub any O₃ molecules from the sample. This is done to create a reference to which the actual sample containing O₃ can be compared to. The reference sample now enters the optical cell where the reference value can be determined.

4. The second part of the sample that contains the O_3 molecules can now enter the optical cell where the UV radiation will be absorbed by any O_3 molecules that are present in the optical cell. The photometer measure the new radiation after absorption has taken place and can compare the radiation to the reference value previously measured. The amount of O_3 is now calculated using these two values.
5. The sample can now exit the optical cell and passes through a flow sensor or pressure sensor to measure the flow of air through the instrument.
6. The next step is the critical orifice inside the manifold which is used to allow the correct amount of air to pass through the instrument.
7. Finally the sample will exit the instrument by being suction created by the pump.

Maintenance of O₃ instruments

Ambient air monitoring instruments are specialized equipment and just like a car these instruments require regular checks and maintenance to ensure that it continues to operate and to ensure the accuracy of measurements and reliability of instrumentation. Table 6.1 provides a schedule of the maintenance and likely repairs that can be performed on an O₃ analyser.

Item	Action	Frequency
Particulate Filter	Change	Bi-Weekly or sooner
Diagnostic Checks	Evaluate	Bi-Weekly
Zero/Span Checks	Evaluate	Bi-Weekly
Multi-point calibration	Calibrate and verify	Every 3 months
Ozone Scrubber	Replace	Annually if required
UV Source	Replace	Annually if required
Pump	Rebuild Head	If flow drops below instrument operational norms
Pneumatics	Clean	Annually if required
Reaction Cell	Clean	Annually if required

Table 6.1: Maintenance and repair schedule.

From table 6.1 the three most important maintenance items are mentioned first with the most important maintenance item being the changing the particulate filter every two weeks.

The particulate filter ensures that no dust or debris enters the instrument as this can contaminate the lenses, optical filters and sensors which will affect the operation of the instrument. Always make sure to change the operating mode of the instrument or switch of the pump when replacing the particulate filter, this way no fine particulates can enter the instrument while changing out the filter. Refer to figure 6.11.

The second important item to check is the diagnostics of the instrument, these are the parameters of the measurements of internal control systems that are in place to ensure optimal operation of the instrument. Most instruments will display a warning on the screen of the instrument if there are any of the parameters that are not within the specified range but it is also important to check all the parameters every two weeks to ensure there were no major changes in any if the parameters.

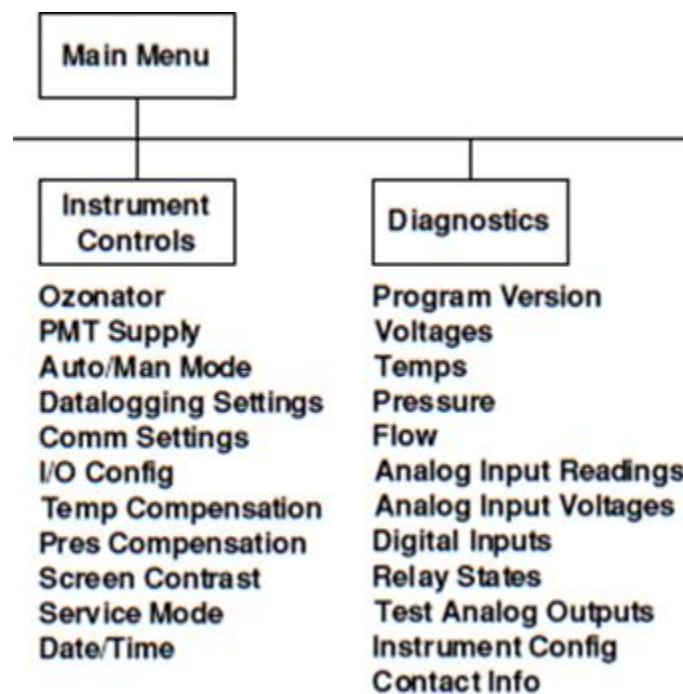

Figure 6.19: Example of instrument menu to check system diagnostics.

O ₃ API Analyser				
Manufacturer	API	Station Name: HAMMANSKRAAL		
Model Number	M400E/T400	Operator Name: CORNÉ GROUÉ		
Serial Number	3082	Date: 6 / 12 / 2017		
Diagnostics check sheet				
O ₃ Parameters	Nominal value / range (1)	Observed (2)	Value 1=2 (Y/N)	Deviation
Range (ppb)	50 – 500 ppb			
Stability	0.02 - 2	0,31		
O ₃ Measure mV	2500 – 4800	3482,3		
O ₃ Ref mV	2500 – 4800	3482,3		
O ₃ Gen mV	80 – 5000	613,1		
O ₃ Drive mV	-	1029,9		
Sample Pressure IN-HG-A	~2" < Ambient	24,4		
Sample Flow cc/min	800 ± 10%	783,5		
Sample Temperature	10 – 50 °C	39,7		
Photo Temperature	58 ± 1 °C	58,0		
O ₃ Gen Temperature	48 ± 3 °C	48,0		
Box Temperature	10 – 50 °C	26,8		
Slope	1 ± 0.3	1,192		
Offset ppb	0.0 ± 5.0	-2,3		
Instrument Faults		0		

Figure 6.20: Example of instrument diagnostics that were recorded.

<https://en.wikipedia.org/wiki/Ozone>

<https://en.wikipedia.org/wiki/Frequency>